

PRINX CHENGSHAN

Prinx Chengshan Company Overview

- Comprehensive version (passenger car tires, commercial vehicle tires, special tires, and air springs)



Contents





About Us

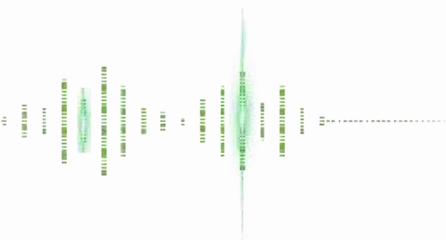

Company Profile

Prinx Chengshan Holdings Limited is a subsidiary of Chengshan Group and was established in 1976. It is committed to the R&D, production, and sales of green, safe, high-quality, and high-performance passenger car tires, commercial vehicle tires, off the road tires, agricultural tires, and air springs.

In the 1990s, established the first independently developed domestic radial tire production line in China.

In 2005, a joint venture was established with Cooper Tire, the second-largest tire manufacturer in the United States.

In 2018, it was listed on the Main Board of the Hong Kong Stock Exchange, with the stock code 1809.HK.

In 2019, the first overseas factory - Prinx Chengshan Thailand Production Base was completed and put into operation.

In 2021, it was awarded the Governor of Shandong Province Quality Award.

In 2024, Prinx brand new commercial vehicle tire product "Fuel-Saving • Smart Mobility" was launched.

In 2025, the second overseas factory broke ground in Kedah Rubber City, Kedah State, Malaysia.

In 2025, the first off-road giant tire 30.00R51 rolled off the production line successfully, and the green intelligent off-road tire factory was put into operation.

In 2025, Prinx brand "Sparkling Elf" series products were released and launched.



Company Scale

Annual Revenue
(100 Million Yuan)



Passenger car tire

Truck and bus tire

Bias tire

Off the road tire

Air spring

Agricultural radial tire

Solid tire

Production capacity:
21.53 million pcs

Production capacity:
9.4 million pcs

Production capacity:
600,000 pcs

Production capacity:
98,000 pcs

Production capacity:
1 million pcs

Production capacity:
50,000 pcs

Production capacity:
100,000 pcs

*Data source: 25-year final report

NO.

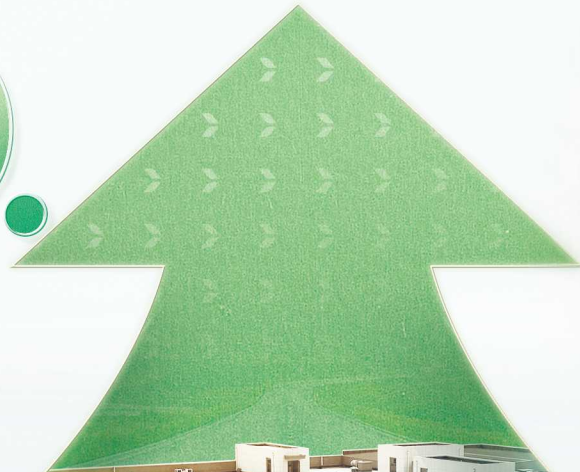

4

Ranking list of Chinese
tire enterprises



Business Layout

Three Intelligent Factories



Intelligent factory in China



Intelligent factory in Thailand



Intelligent factory in Malaysia (under construction)

Prinx Chengshan has always been committed to empowering global partners and creating excess value for them.

We have nearly 600 first tier distributors in 169 countries and regions across 6 continents, empowering over 60,000 stores worldwide and jointly fulfilling our mission of leading innovation in tires.

Important Honors



2021 Shandong Governor Quality Award

The Second Prize of the National Science and Technology Progress Award

Energy Efficiency Leader Benchmarking Enterprise

Annual Top Ten Innovation and Development Award

National May Day Labor Award Certificate

Top 10 most Influential Chinese Tire Brand

EcoVadis Gold Certification

National High-tech Enterprise

Best Industrial Manufacturing Company

China's 500 Most Valuable Brand

Top 500 in China's Petrochemical Industry

2021 Industry Quality Model Award





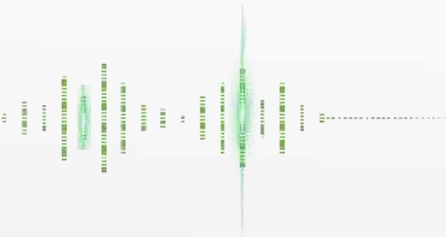

R&D Strength

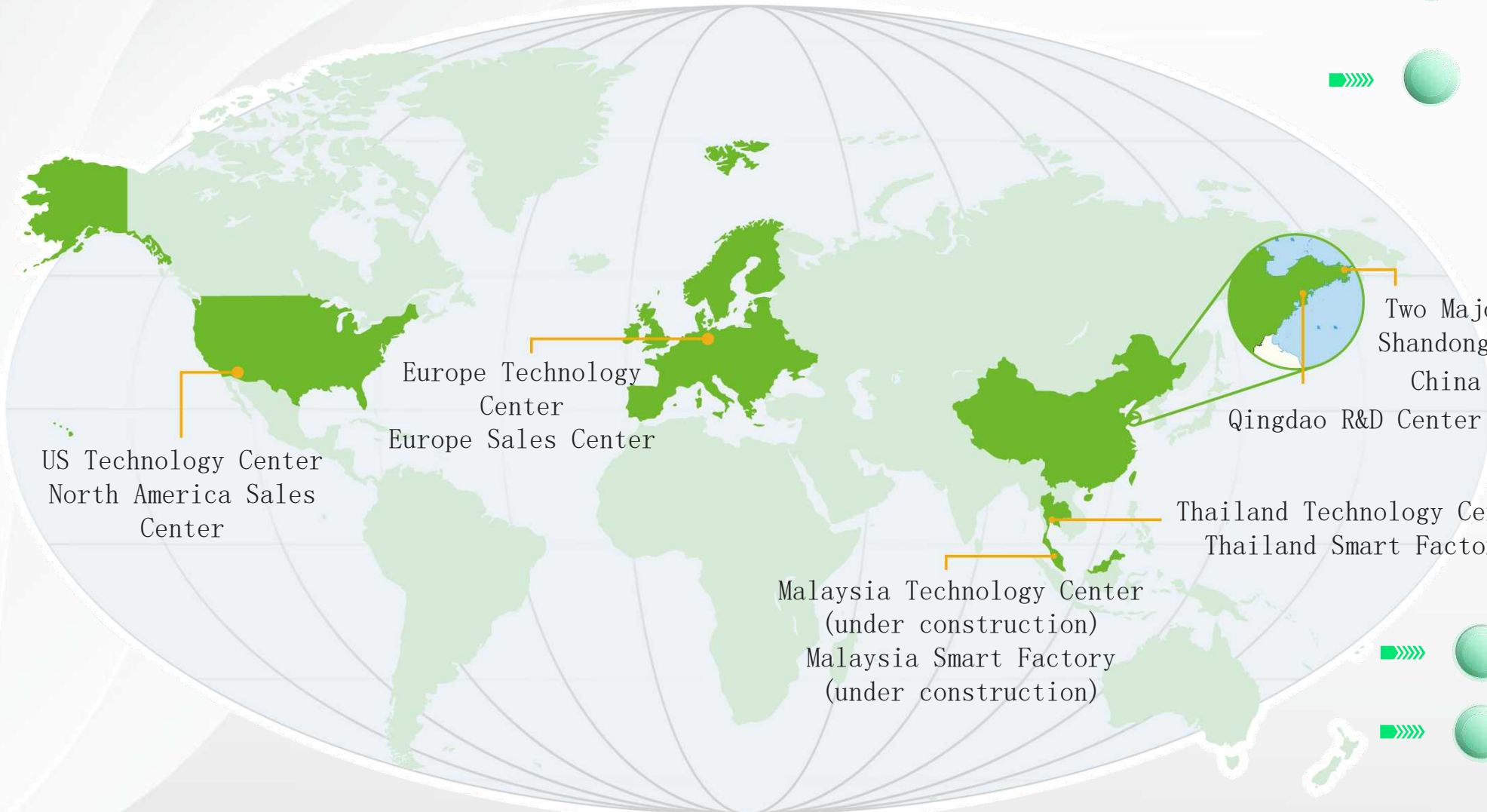
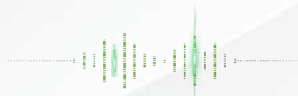

R&D Layout



- 

Two Major R&D Centers
- 

Four Major Technology Centers

Two Major R&D Centers
Shandong Smart Factory
China Sales Center
Qingdao R&D Center

Thailand Technology Center
Thailand Smart Factory

Malaysia Technology Center
(under construction)
Malaysia Smart Factory
(under construction)

- 

Three Major Production Bases
- 

Three Sales Centers

R&D Achievements

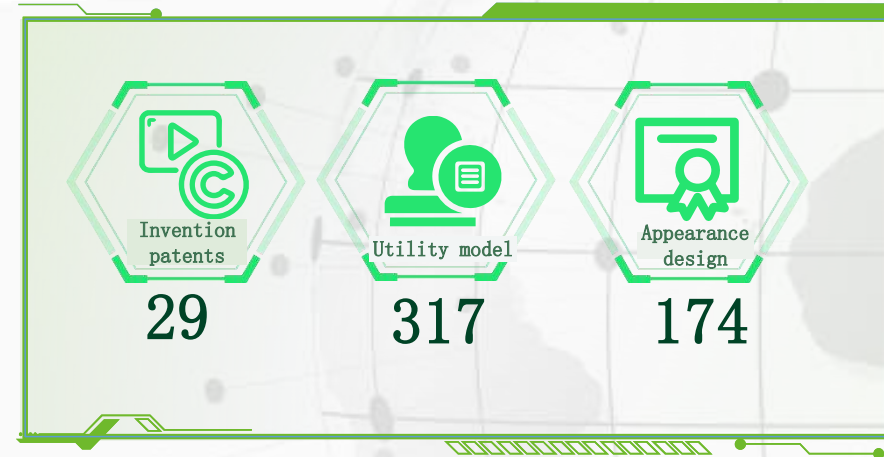
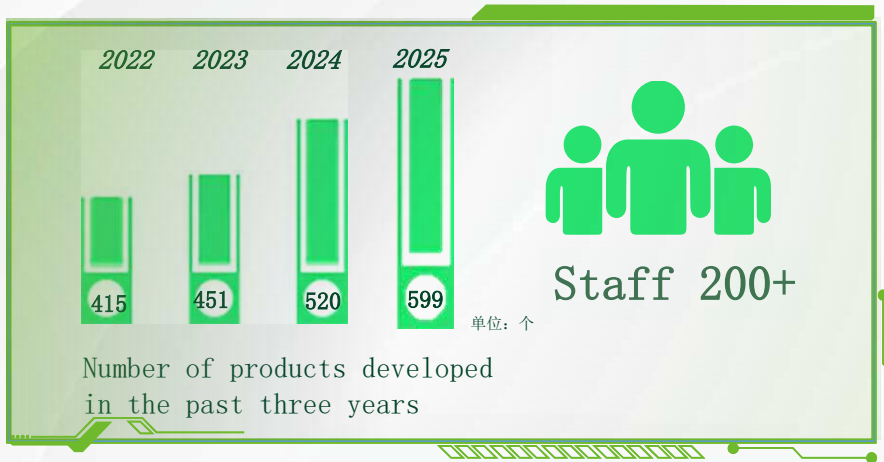

● Firstly put forward the concept of multi-scale tire life cycle

● Participated in the formulation and revision of more than 30 relevant national industrial standards

● First established an innovative R&D center in China in the 1990s

R&D Capability

Appearance Design

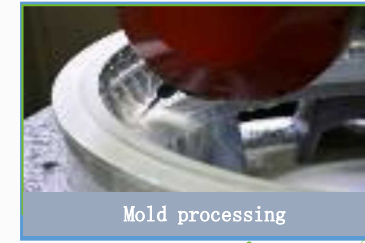
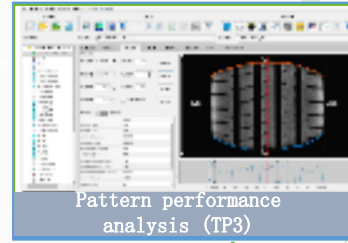
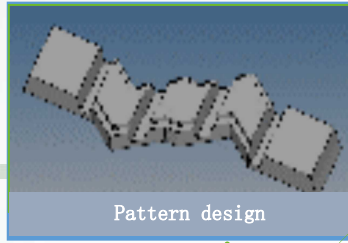

Compound Design

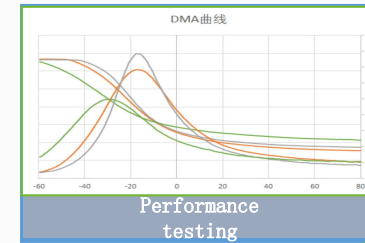
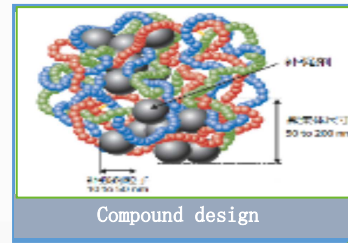
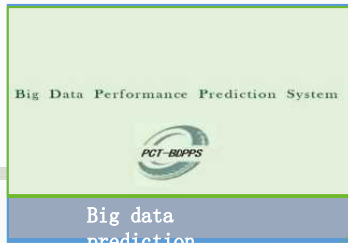

Structural Design

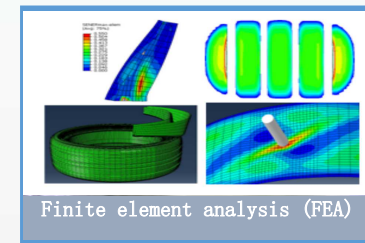
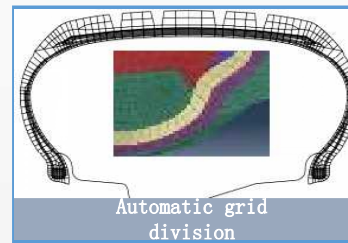
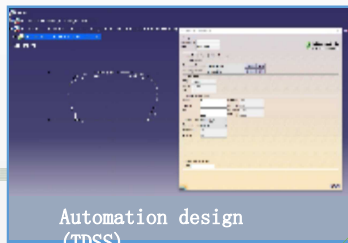

By extensively utilizing computer-aided and performance prediction technologies, we have the ability to quickly develop high-quality products and apply advanced technologies

Advanced technologies in R&D of passenger car tires

- ▶▶▶▶ ● Low rolling resistance technology
- ▶▶▶▶ ● Silenteck®
- ▶▶▶▶ ● Vantablack technology
- ▶▶▶▶ ● Intelligent tire technology
- ▶▶▶▶ ● Aging durability technology
- ▶▶▶▶ ● Inktech®
- ▶▶▶▶ ● Healtech®
- ▶▶▶▶ ● Customized technology
- ▶▶▶▶ ● Overload technology

Low rolling resistance technology

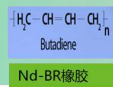
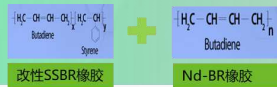
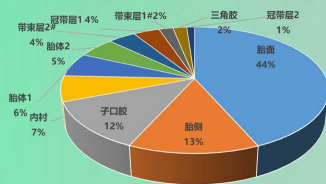

Contour design is optimized, shear strain is reduced, and energy consumption of each component is reduced

Combining FEA with tire validation to conduct extensive research on the correlation with rolling resistance

Modified and functional raw materials are applied to reduce heat generated by tire components

● XLAB COMFORT EV of Prinx

● XNEX SPORT EV of Prinx

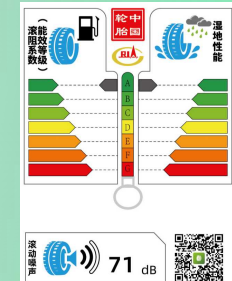
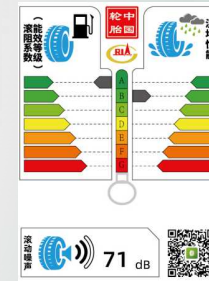

Low-temperature and low rolling resistance performance exceeds that of international first-tier brands, N/kN

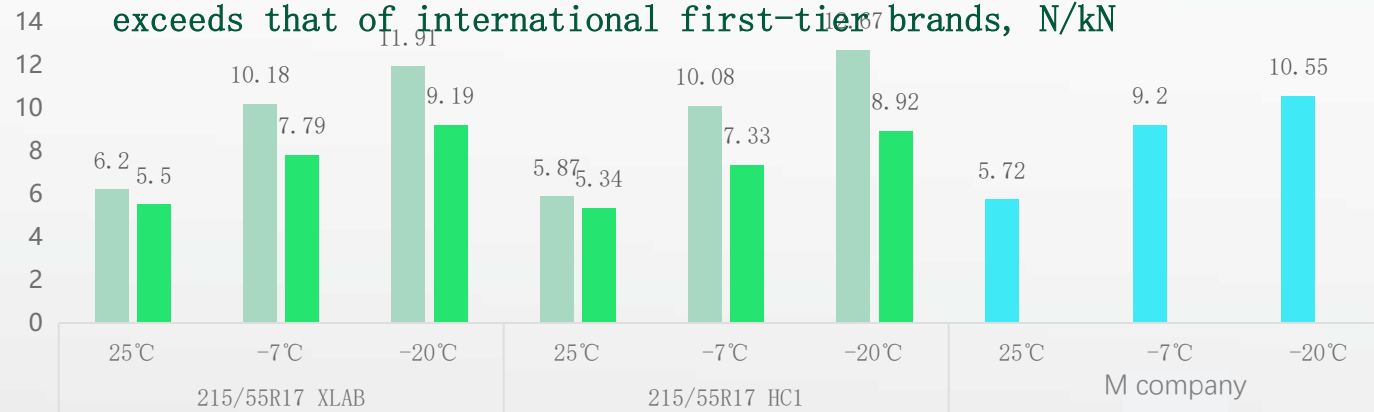

■ Conventional scheme

■ Low-temperature and low rolling resistance scheme

Inktech®

Velvet technology application products

The first domestic tire enterprise to adopt large-scale velvet industrialization

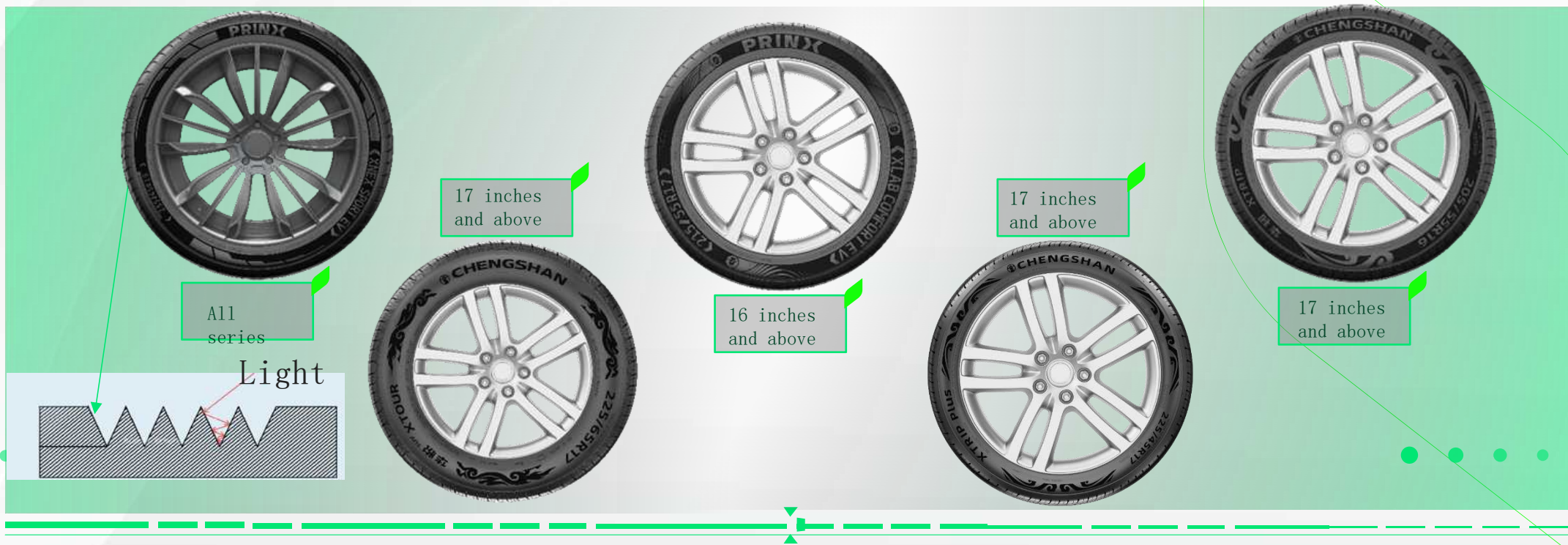

Silenteck®

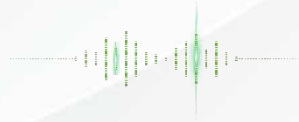

Silenteck® has successfully passed the following durability tests, without any damage to the tires:

- 80kph×10d×24hrs indoor low-voltage high load durability test
- 120kph×5d×24hrs indoor barrier durability test
- CN standard durability test after oven aging (50%/50% N2/O2, 65°C, 8 weeks)
- 2,000-km low-temperature road test (-25°C, Mohe)
- 2-million km road test for 40 vehicles
- CATARC Yancheng noise test: Cavity noise peak reduced by 12.7dB; in-vehicle noise reduced by 4dB



Patent number: ZL 2022 3 0091785.3



Testing of 255/45R19

Silenteck® is the unique noise reduction technology of Prinx Chengshan, which can significantly reduce noise at all frequencies.

Healtek®

Healtek®

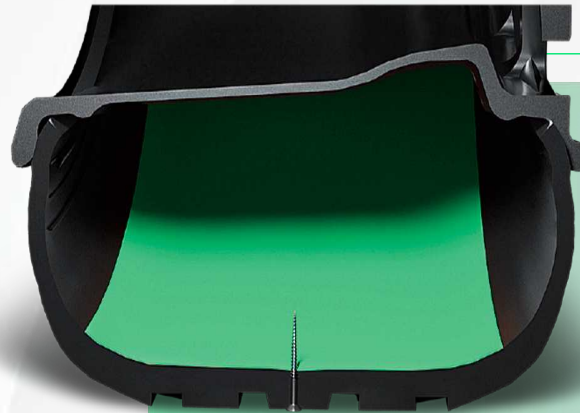

Healtek has successfully passed the following verification:

Air tightness with nail/after nail pulling

Indoor high-speed and durability tests

VW car low-temperature road test (-25° C, 2.000 km)

Accumulated 2-million km of road tests in three cities (Shenyang, Hefei, and Chengdu)

High speed

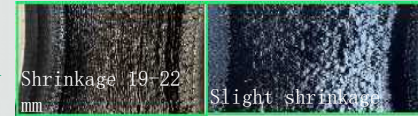

Durability

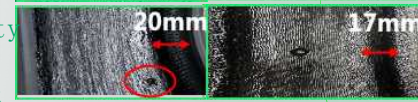

Embrittlement

-30° C

Air impervious liner



Chipping 98%

Good adaptivity 99%



Self-sealing+acoustic foam

Healtek® is the unique self-sealing technology of Prinx Chengshan, which can protect tires from the effects of blowouts, punctures, and air leaks, and alleviates user's anxiety about replacing the tire with a spare one.

Infinite-BLK

Infinite-BLK

We have adopted the brand-new ozone and crack resistance technology, which effectively enhances the blackness and texture of the tire sidewalls, and reduces the precipitation of small molecules. It comprehensively improves the cracking problem of tires in the middle and later stages of use, allowing the tire sidewalls to remain fresh and long-lasting throughout the service cycle.

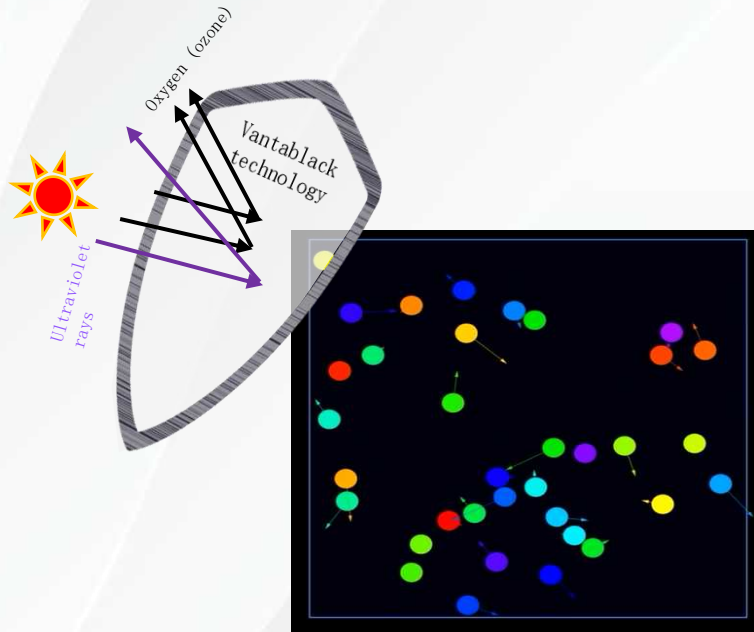

Schematic diagram of small molecules in tires

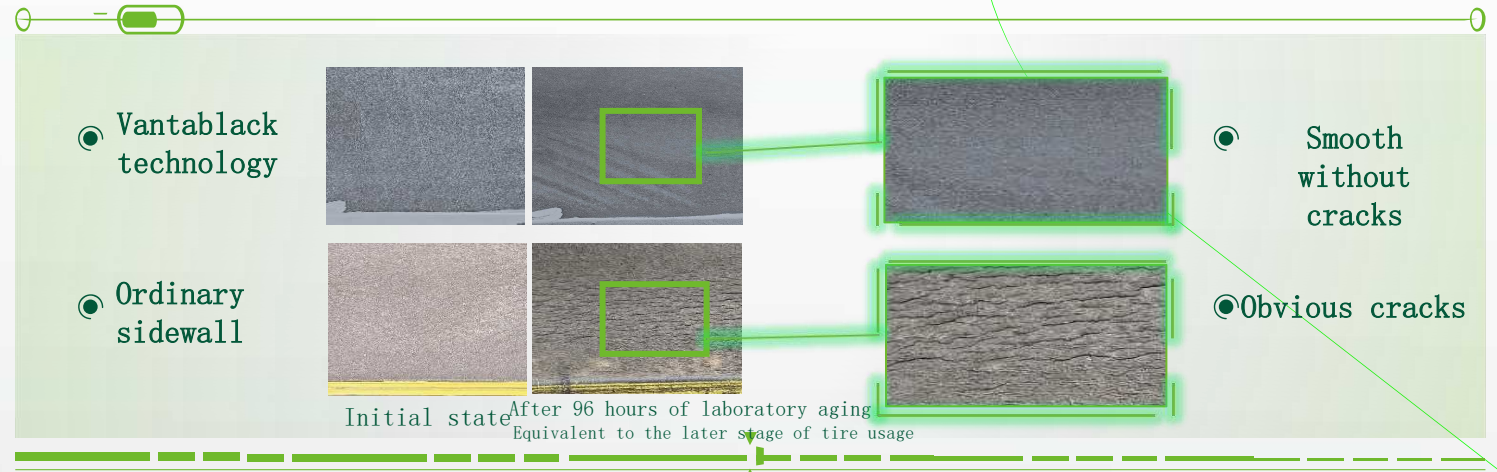

Customized Technology

Colored Sidewall Technology

Customized colored sidewall meets individual needs

- ▶▶▶ The color technology can be realized
- ▶▶▶ The colored compound solves the problem of oxidation and discoloration.



Laser Carving Technology

Laser carving can be used for customized pattern on tires



Intelligent Tire

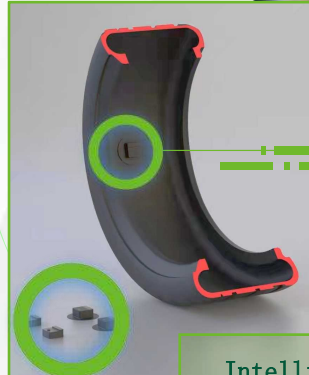

Intelligent tire sensor

Braking system
Apply brake/change torque

Control strategy

Predict vehicle motion trajectory

Intelligent tire system

Measurements of intelligent tire
Contact pressure of tire
Slip angle of tire
Slip ratio of tire
Tire-road friction coefficient
Road roughness

Predict position variables

Advantage: The unknowns to be estimated is reduced; the unknowns can be estimated more effectively

Values measured by the original system
Wheel speed
Steering wheel angle
Lateral acceleration
Yaw rate
Brake pressure

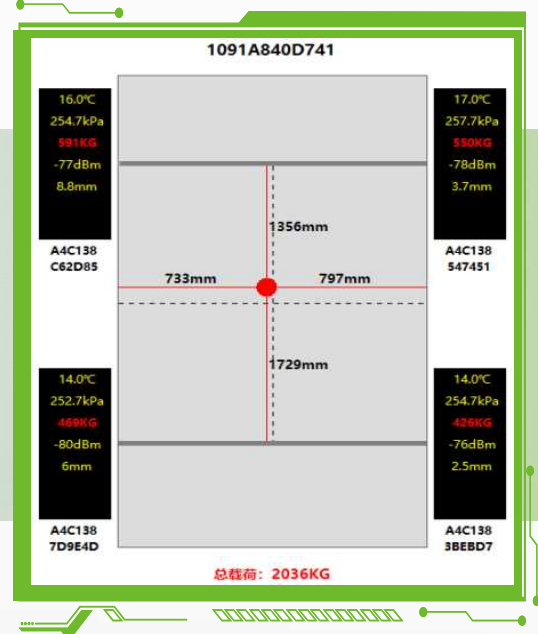
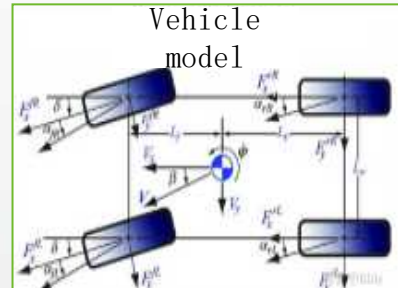

- Provide accurate centroid parameters for vehicle control
- Sense cornering stiffness of tires
- Sense pattern groove depth of tires

Overload technology

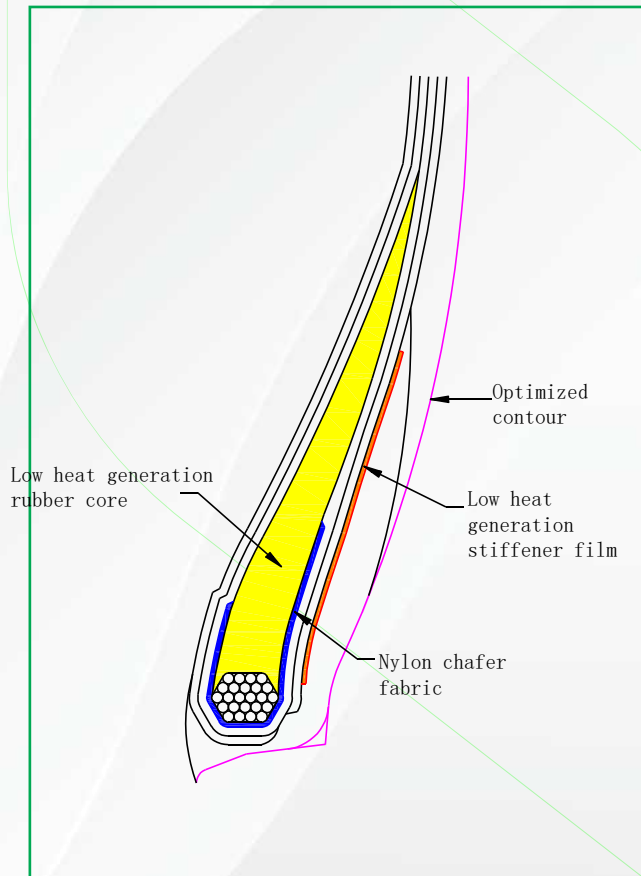

Application of super strong steel wire improves puncture-resistance by 43%

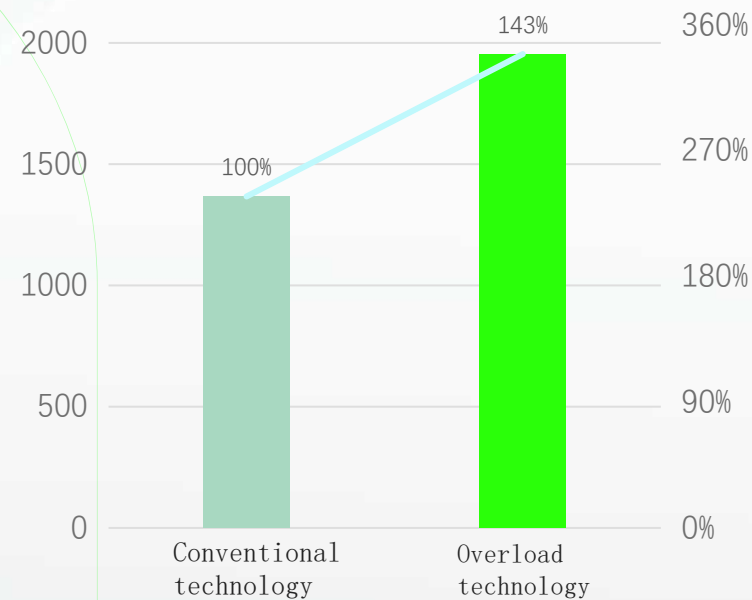

Overload technology reaches the international first-line level

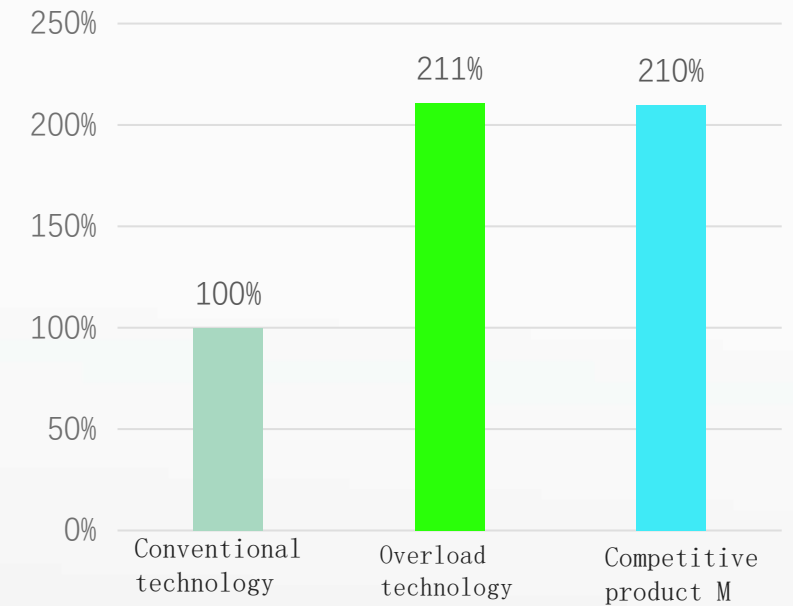

Overload technology effectively meets the requirements of new energy vehicles and light-duty trucks for high load capacity

Aging durability technology

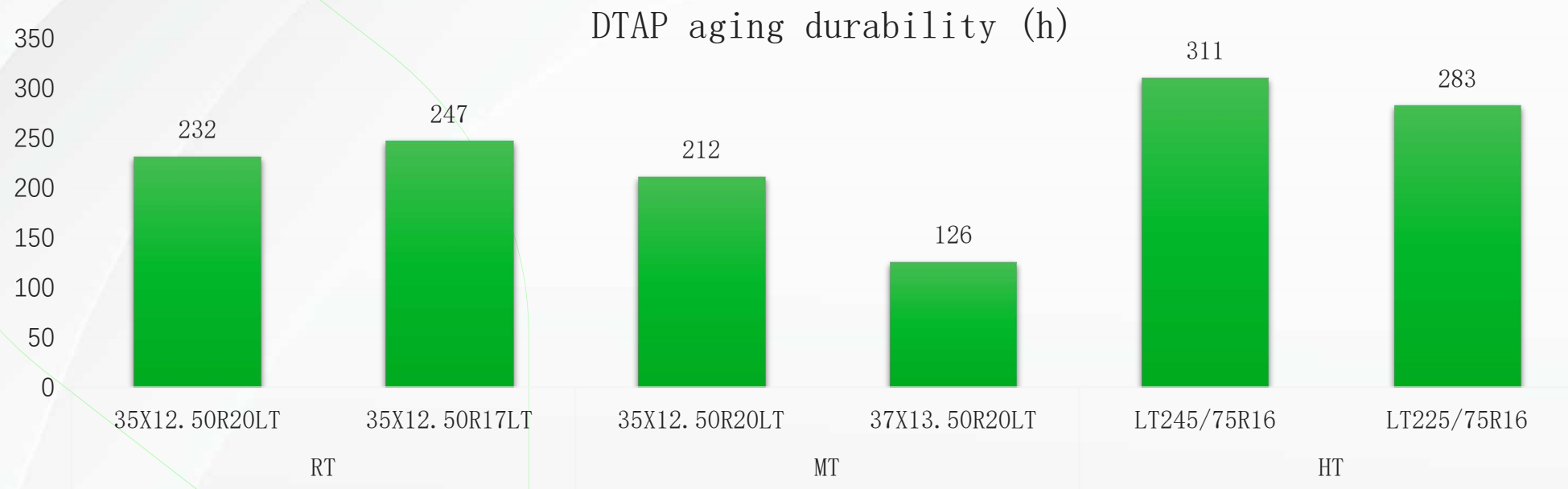

*Durability of tires after thermal oxidative aging (50%/50% N₂/O₂, 65° C, 5 weeks)

▶▶▶▶▶ The aging durability time is far longer than the industry average of 60 hours, effectively ensuring the long-term safety of the tires



Advanced Technologies of Commercial Tires

▶▶▶▶▶ ● Green Profile Theory--ECOC

▶▶▶▶▶ ● Green Profile Theory--GPT

▶▶▶▶▶ ● Bead Wrapped Chafer

▶▶▶▶▶ ● Matrix Technology

▶▶▶▶▶ ● High Wear Resistance Technology

▶▶▶▶▶ ● Anti-uneven Wear Design

▶▶▶▶▶ ● Bead Endurance - BET

▶▶▶▶▶ ● Smart Tire -XCHIP

Green Profile Theory--ECOC

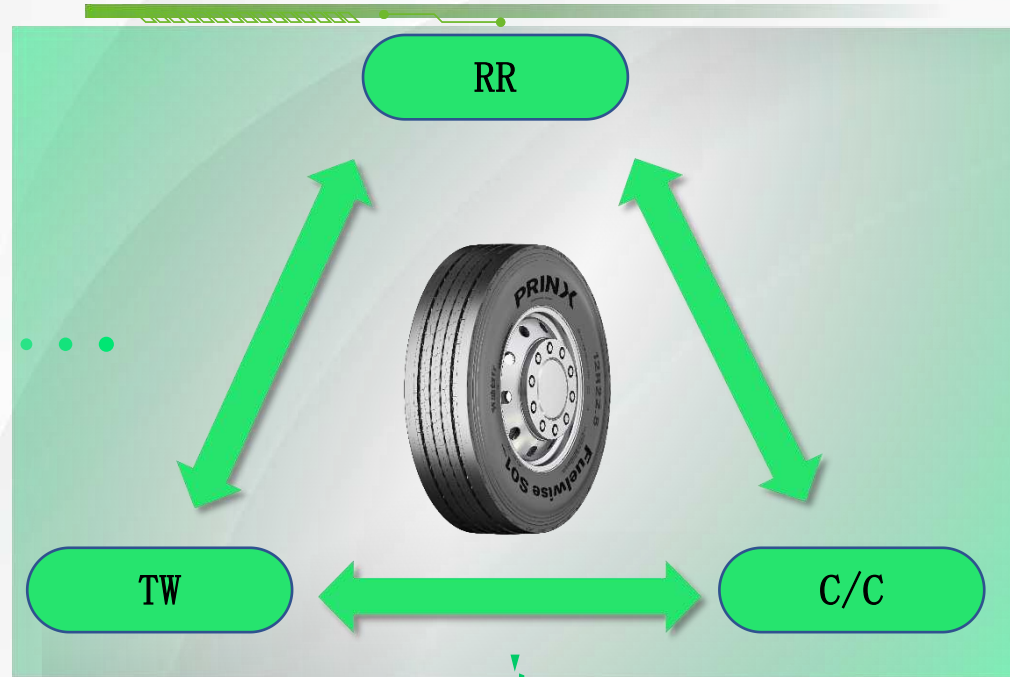

- Ultra-condensed Ribbed Smoked Sheet
- High structure & high SA, WSD filler blending high molecular polymer provides lower RR and higher fracture resistance.
- High speed tandem mixer facilitates carbon and silica dispersion under relative low temperature.
- The organic-inorganic/nitrogen-oxygen hybrid components creates a triple network, simultaneously enhancing the dynamic fatigue performance

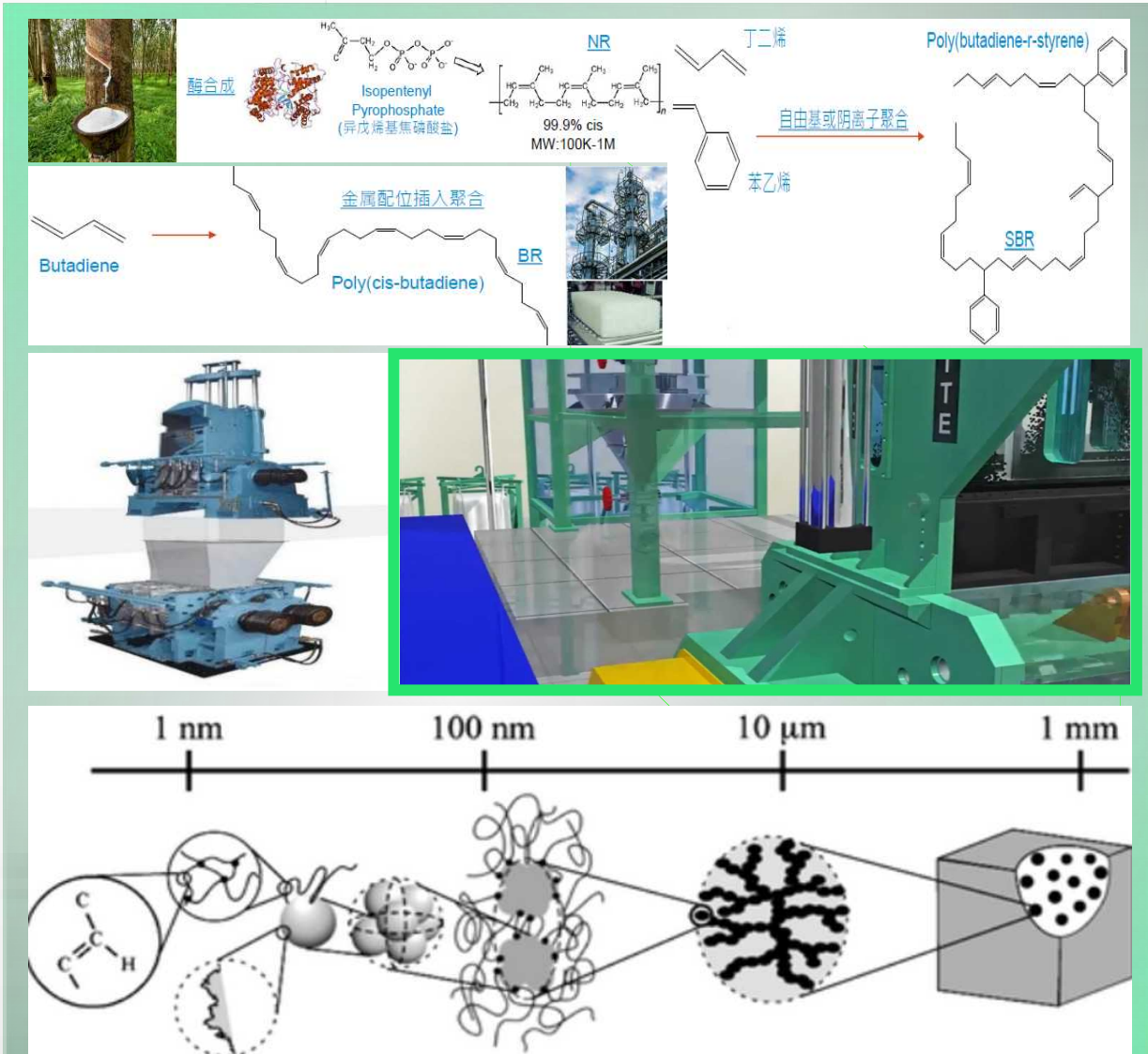

酯合成
 Isopentenyl Pyrophosphate (异戊烯基焦磷酸盐)
 NR
 99.9% cis
 MW: 100K-1M
 丁二烯
 苯乙烯
 自由基或阴离子聚合
 Poly(butadiene-r-styrene)
 SBR
 Butadiene
 金属配位插入聚合
 Poly(cis-butadiene)
 BR

1 nm 100 nm 10 μm 1 mm

Green Profile Theory- GPT

Reduced heat generated in tread cap

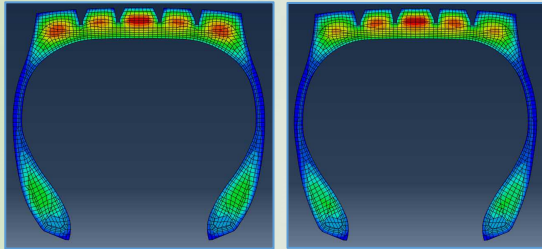

Profile design is optimized, shear strain is reduced, and energy consumption of each component is reduced

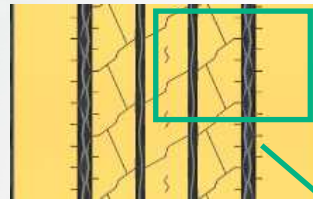

Middle of the tread is designed as an integral whole, reducing the deformation of tread cap

The pattern groove in the middle is optimized, reducing rolling resistance

Unique pattern design can improve tread stiffness, reduce rolling resistance and improve abrasion

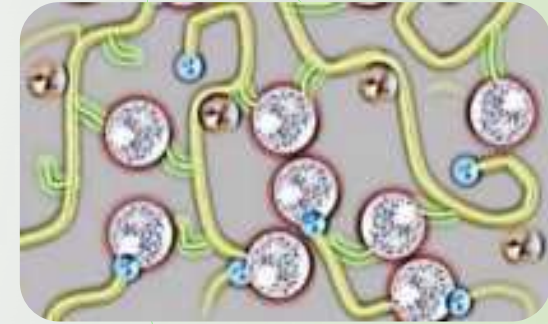





The silica compound with tandem mixing ensures lower heat build-up and higher wear resistance

A

<4.0
N/KN



B

Brand	Prinx Chengshan		MI	
Product	S70	D40	Z2	D2
Pattern				
Tread surface width	266	280	266	282
Pattern depth	13.0	13.5	11.8	13.5
Rolling resistance coefficient, N/KN	3.9	4.3	3.9	4.2

Bead Wrapped Chafer- BWC

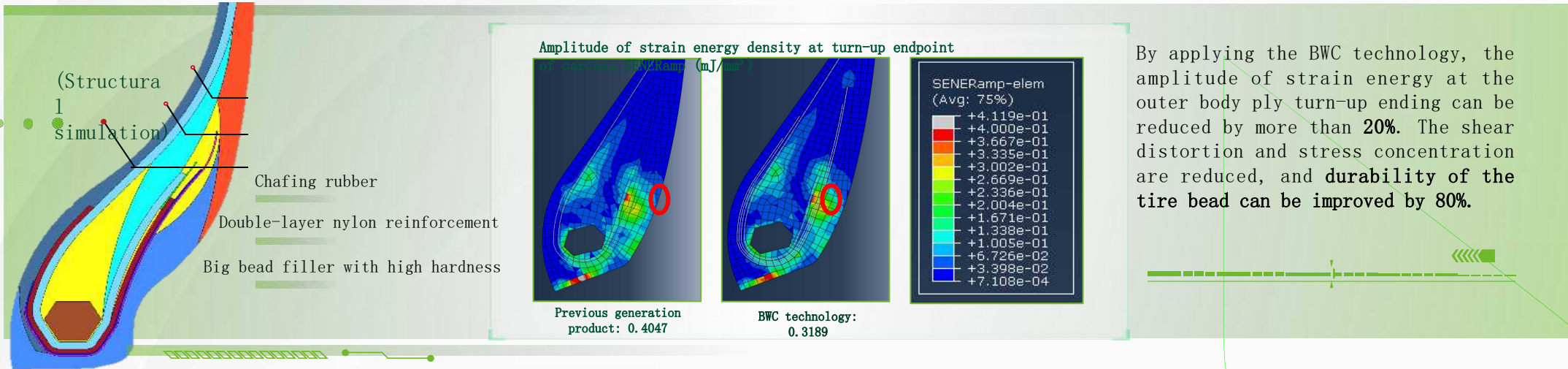

Heavy-duty H series

- Historical inheritance: **H**onor
- Building together: **H**elpful
- Higher quality: **H**igh
- Heavy responsibility: **H**eavy

Durable bead with comprehensively improved performance

(Compared to the previous generation products that are not applied with BWC technology)

Toughness of the bead is improved, ensuring less deformation of the tire when being compressed by rim under high loads.

The fullness of the bead is improved, avoiding reversed arch and changing of distribution of force on the bead.

The body ply and chipper turn-up endpoint are tightly bound, reducing the probability of separation.

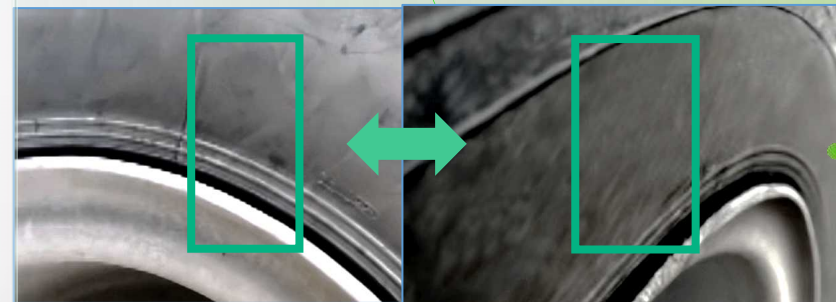

Before application (the bead is slightly sunken)

After application (the bead is full)

Matrix Technology- MT

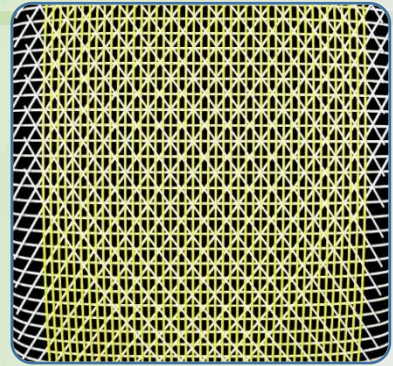
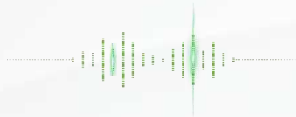

- ▶▶▶▶ The high-elongation steel wire with a length of over **100** meters is continuously winded perpendicular to the body ply and cover the tread cap, forming a stable intersecting network structure with belt cord.
- ▶▶▶▶ Restriction factor of the body ply is increased, effectively ensuring tire performance during high-load and high-speed operation.

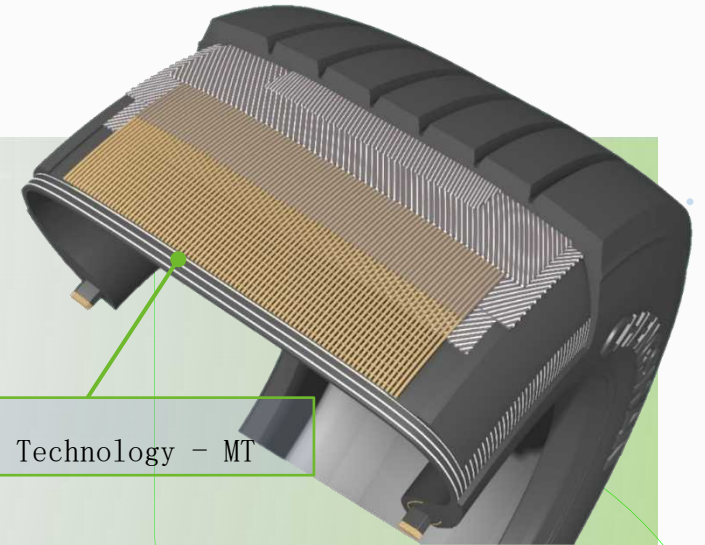

Matrix Technology - MT

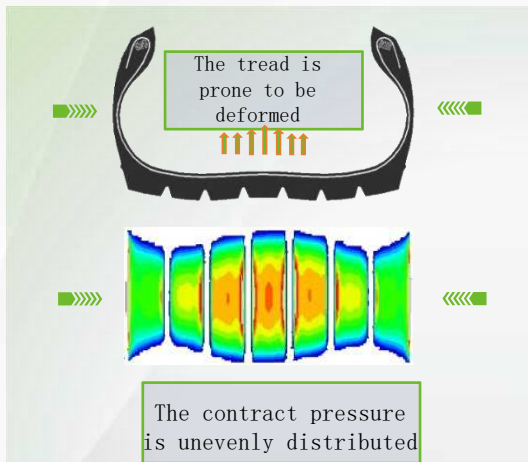

This technology is not applied

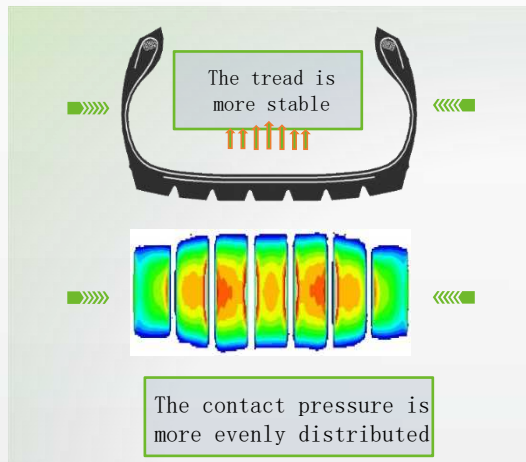

This technology is applied

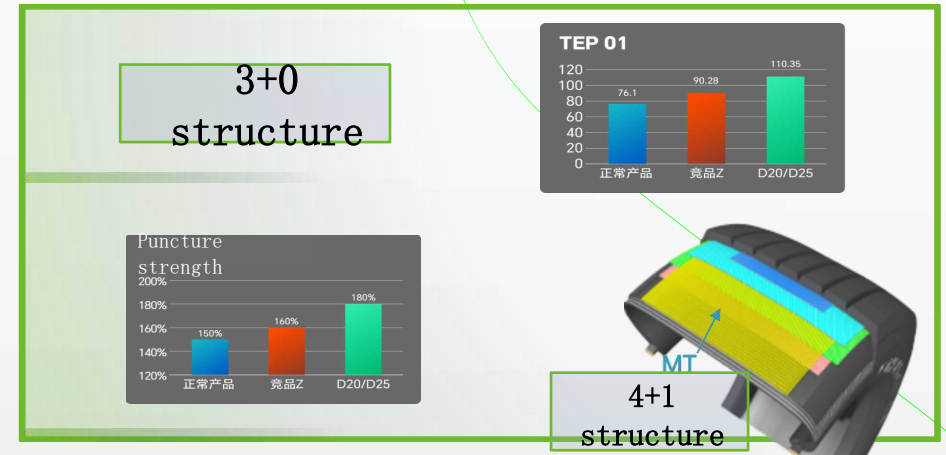

The performance is improved

(Compared with the products that this technology is not applied)

High Wear Resistance Technology – HWR

Optimized Profile

Reduce heat generation

The tread is more stable

Strong Framework

Ultra-wear-resistant compound

Wear resistance 100%

Wear resistance 124%

High-wear-resistant compound

Ultra-high wear-resistant compound

Detailed description: This diagram illustrates the HWR technology. On the left, a cross-section of a tire tread is shown with a heat map overlay. A red arrow points downwards from the tread surface, labeled 'Reduce heat generation'. The tread profile is labeled 'Optimized Profile'. In the center, a tread cross-section is shown with the text 'The tread is more stable' and five red arrows pointing upwards from a textured surface below, labeled 'Strong Framework'. On the right, two circular gauges represent wear resistance. The first gauge, labeled 'High-wear-resistant compound', shows 100% wear resistance. The second gauge, labeled 'Ultra-high wear-resistant compound', shows 124% wear resistance. A box labeled 'Ultra-wear-resistant compound' is positioned above the 124% gauge.

Anti-uneven Wear Design- AUD

● Optimized block and groove ratio

Abrasion energy

Abrasion energy

Steer

Drive

Detailed description: This block focuses on 'Optimized block and groove ratio'. It features a diagram at the top showing two wave-like lines representing 'Abrasion energy' with arrows pointing towards each other. Below this are two photographs of tire tread patterns. The first photo shows a tread with diagonal grooves, and the second shows a tread with vertical grooves. At the bottom, there are two buttons: 'Steer' with a right-pointing arrow and 'Drive' with a left-pointing arrow.

● Optimized footprint

Detailed description: This block focuses on 'Optimized footprint'. It contains two sets of heat maps showing the contact area of a tire tread. The top set shows four vertical strips of heat maps, and the bottom set shows two larger heat maps. Below the heat maps are two photographs of tire tread patterns, one with diagonal grooves and one with vertical grooves.

● Improved shoulder stiffness

Detailed description: This block focuses on 'Improved shoulder stiffness'. It features a cross-sectional diagram of a tire shoulder with a green arrow pointing to a specific layer. Below the diagram is a photograph of a tire tread showing the shoulder area.

Bead Endurance – BET

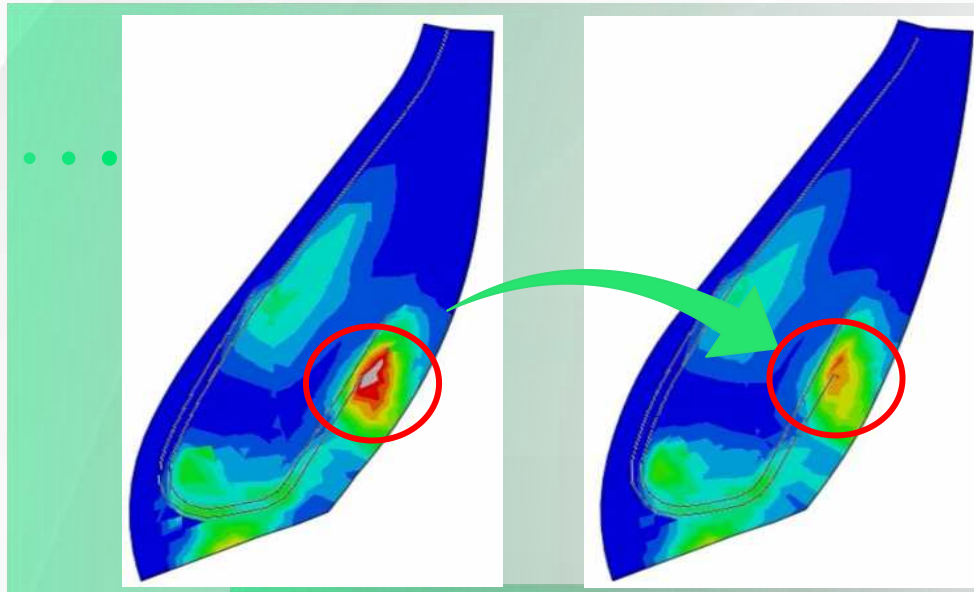

Optimized profile reduces the strain energy at the body ply turn-up ending and chipper ending, thereby improving bead endurance

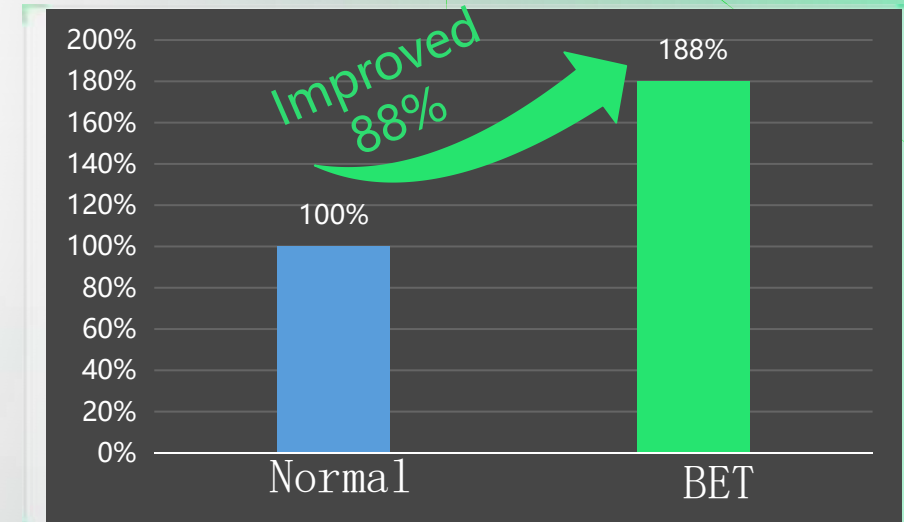

Bead Endurance Test

Smart Tire-XCHIP



Real-time pressure monitoring

Real-time temperature monitoring

Tire tread depth monitoring

Real-time tire load monitoring

Road surface perception

GPS

Driver driving behavior analysis

Tire removal/installation and rotation records

Whole-life cycle mileage statistics

Tire asset management



Smart Tire -XCHIP

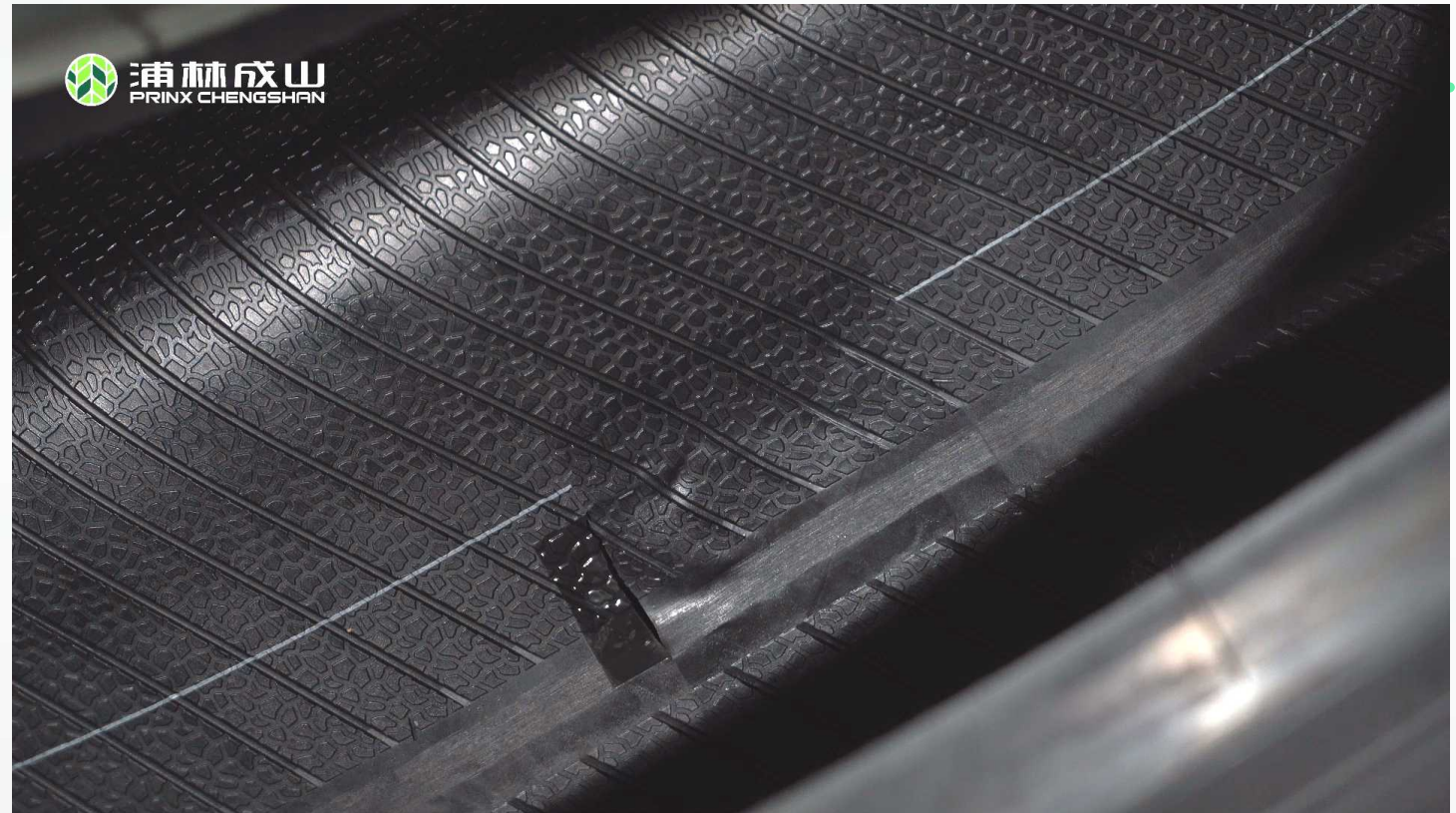

- The patented pocket-type structure enables extremely convenient sensor installation
- The measurement of tire temperature, pressure, load, and groove depth has been commercialized

Advanced Technologies of Off-the-road Tires

- Profile Balance Theory
- Compound Technology
- New Tread Winding Technology
- Product Category of off-the-road Tires



Profile Balance Theory

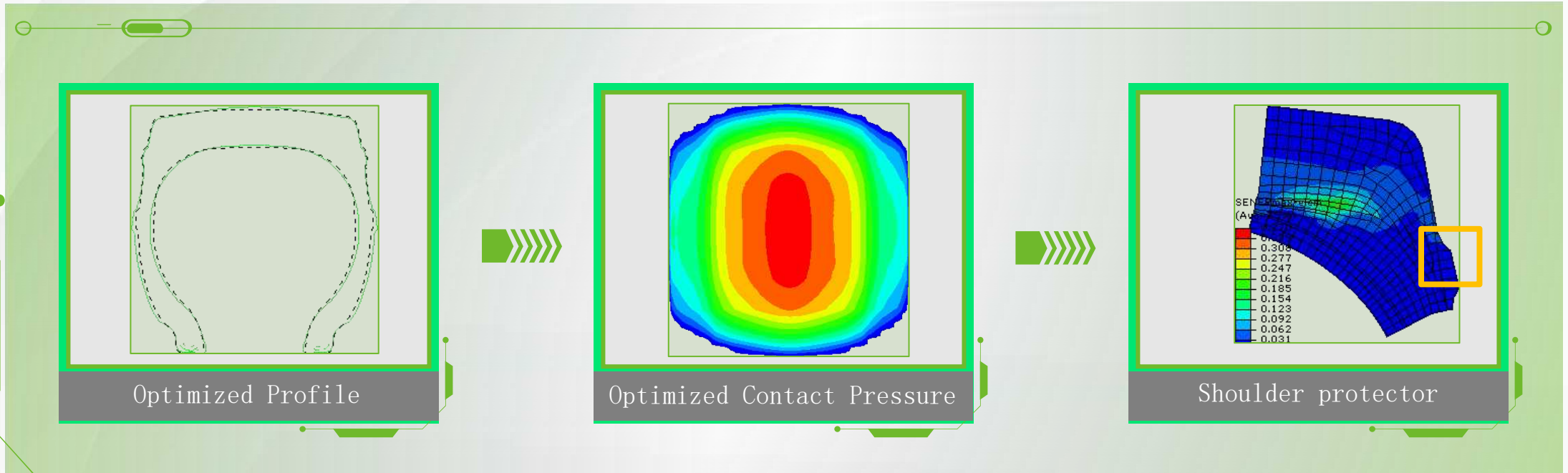

- ▶▶▶▶ The profile design is optimized and strain capacity of the belt ply is reduced, ensuring good durability of tires.
- ▶▶▶▶ Optimize the distribution of contact pressure to ensure high tire wear.
- ▶▶▶▶ Adopt shoulder protector design to reduce the damage to sidewall caused by the falling stones.

Compound Technology

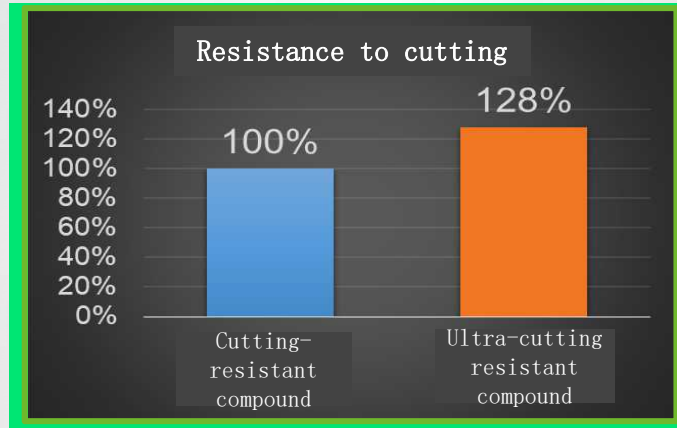
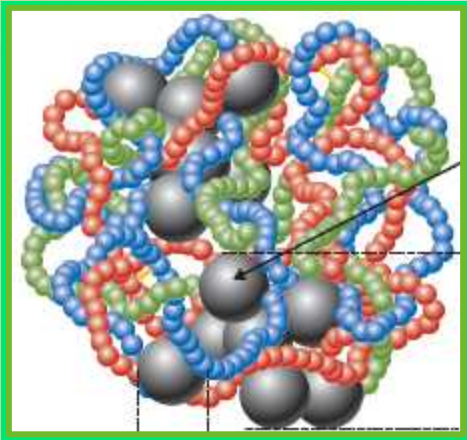
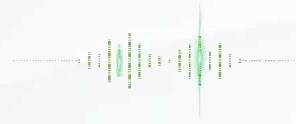

Resistance to puncture and tear



By combining the polymer system, nano reinforcement material, and new resins reasonably, excellent resistance to wear, puncture, and chipping & chunking of the tire is ensured and service life and safety of the tire is improved.

New Tread Winding Technology

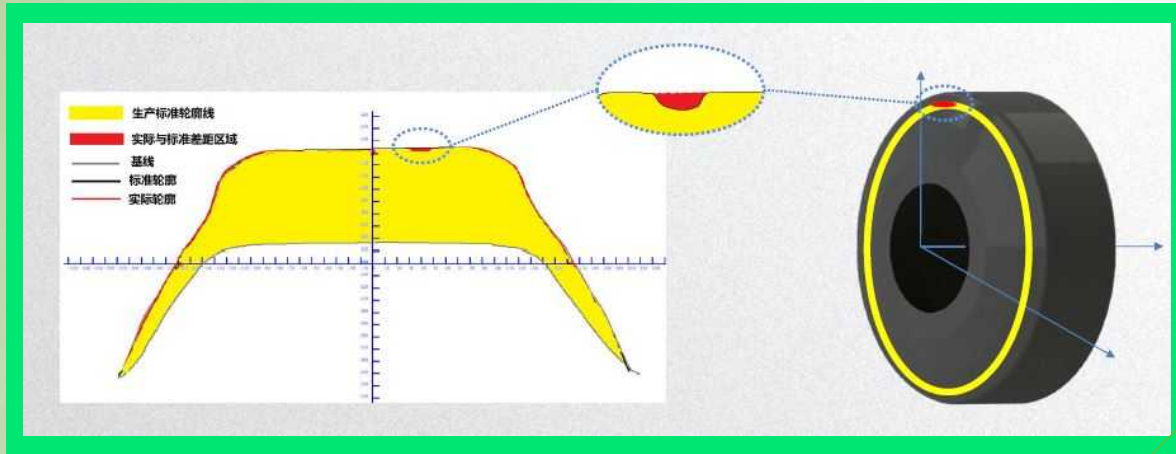
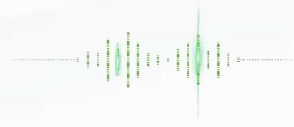

The actual profile data is compared with the standard profile data to calculate the data difference. The extruding die design is optimized, porosity of the tread winding is reduced by 50%, and tread density is improved, ensuring the wear and tear resistance of the tire.

Product Category of Off-the-road Tires

All-steel radial tire - tire for wide-body dump truck



All-steel radial tire - tire for loader



All-steel radial- tire for underground scraper



Bias truck tire - tire for loader



Advanced Technologies of Air Spring

▶▶▶▶▶  Low Heat Generation Technology

▶▶▶▶▶  Ozone Resistance Technology

▶▶▶▶▶  Fatigue Resistance Technology



Air Spring – Low Heat Generation Technology+Ozone Resistance Technology

A special compound for ozone-resistant air spring with low heat generation is developed by screening raw materials.

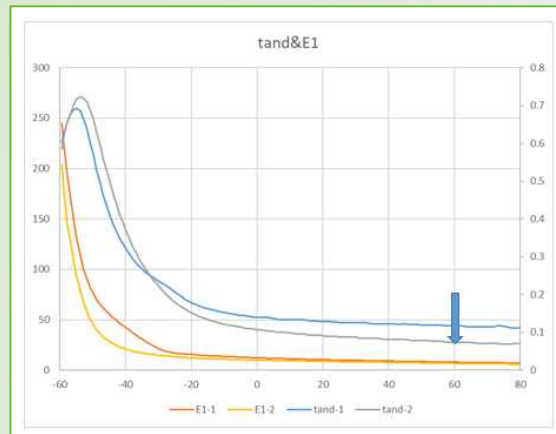

The dynamic heat generation is significantly reduced, and the temperature scanning loss factor $\tan \delta$ @ 60° C is reduced by about 47%.

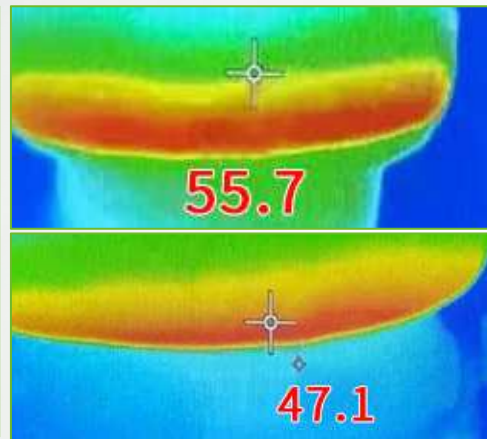

The temperature in the flexing area of the assembly is decreased by (8 - 10)° C.



Under conditions of ozone concentration of 200 pphm, elongation of 20% and 40° C, the air spring gum strip has no cracks for more than 130 hours.

Air Spring – Fatigue Resistance Technology



A special compound for fatigue-resistant air spring is developed by screening raw materials.



- ▶▶▶▶ The air spring rubber has no cracks after 8 million times of flexing
- ▶▶▶▶ test.

The air spring assembly can withstand 10 million times of fatigue test.

Product Category of Air Springs

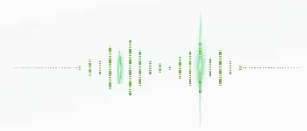

Rolling Lobe Air



Scope of application: trailer chassis suspension

Bellows Air Spring



Scope of application: lift axle bladder

Sleeve Air Spring

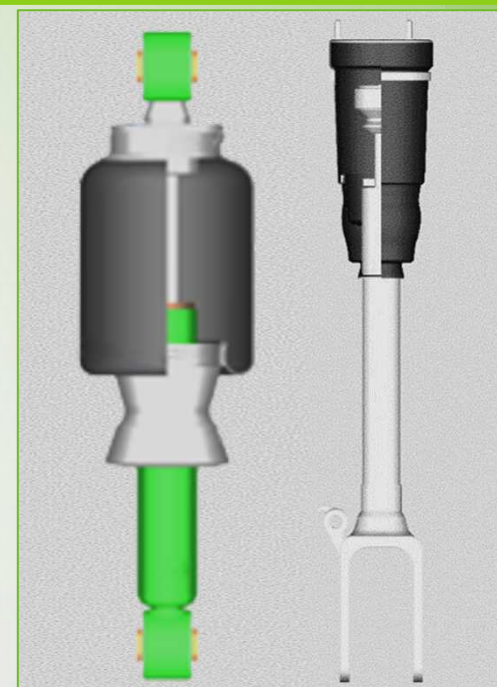

Scope of application: driver's cab, seat, and passenger car suspension airbag

Testing Capability

Physical and Chemical Testing

Finished Product Testing

Vehicle Testing



R&D

Physical and Chemical Testing

Raw material quality approval

Development and evaluation of new material technology

Compound performance evaluation

Reverse analysis of competitive products

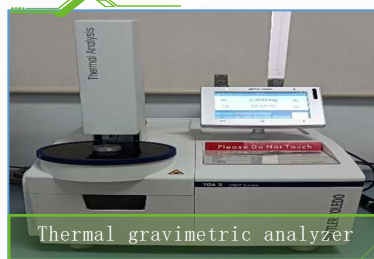

Finished Product Testing – Tires

Safety

Economy

Comfort

Handling Stability



Shearography non-destructive detector



Tire endurance and high speed testing machine



Bead compression test machine



Air tightness tester



Modal force transfer tester



Rolling resistance test machine



Footprint analyzer



Tire aging room



Stiffness test machine



V-box



Atomic absorption spectrometer

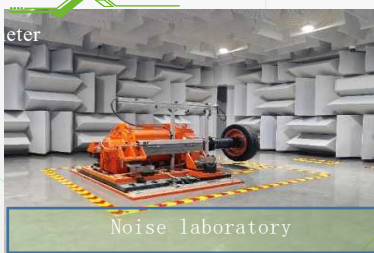

Noise laboratory



Force and moment test machine (2021)



Proving ground (rented)



Actual wear test

Meet constantly stringent regulatory requirements

Support development of OE technology and NVH problem diagnosis

Provide value beyond customer expectations

Finished Product Testing – NVH Analysis and Diagnosis

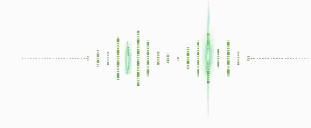

»»» Tire mode and force transfer function «««

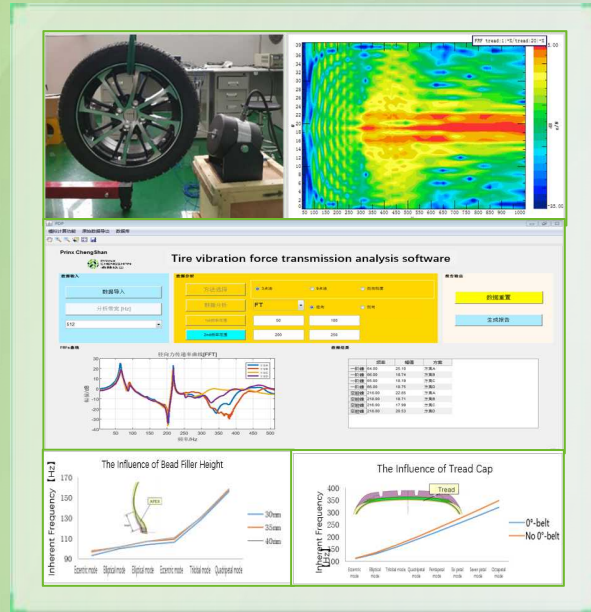

»»» Noise spectrum analysis of vehicle test «««

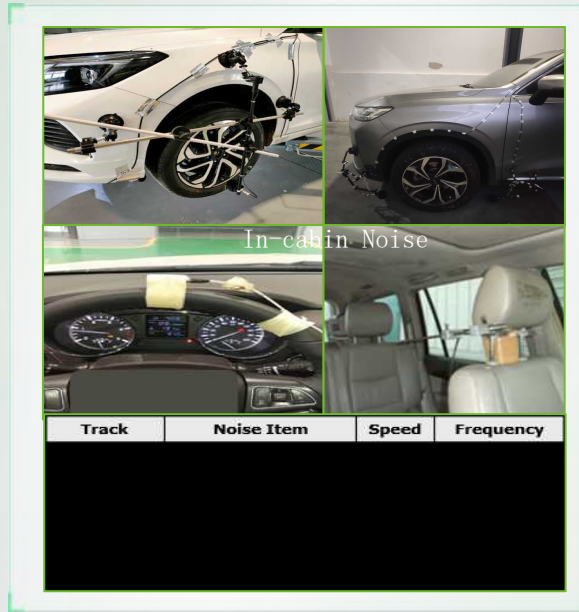

»»» Tire axle force testing «««

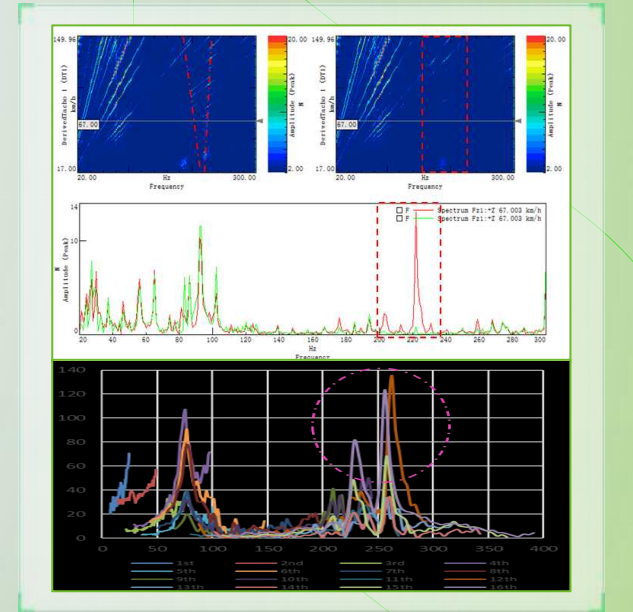

Finished Product Testing – NVH Analysis and Diagnosis

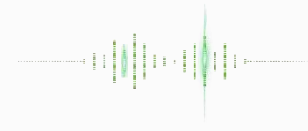

Tire and vehicle NVH analysis and diagnosis

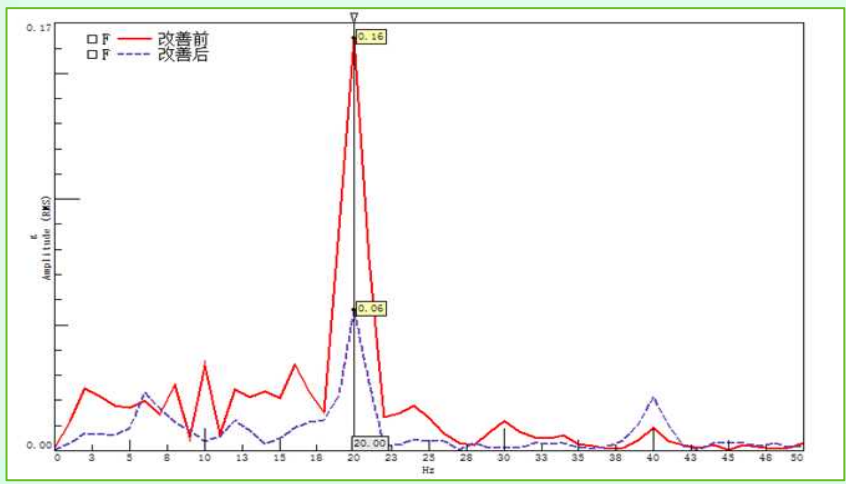
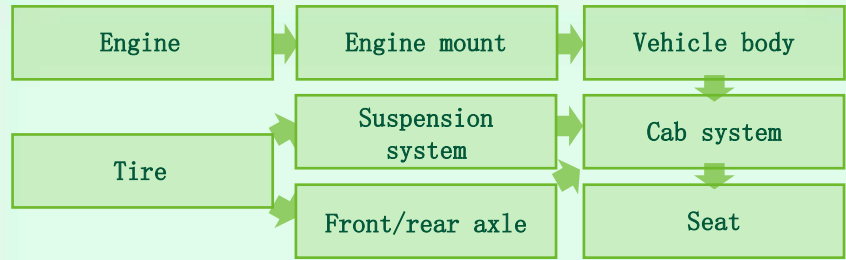

Tire pattern noise separation technology

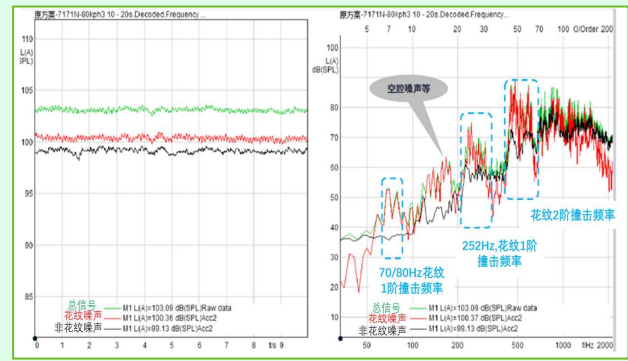
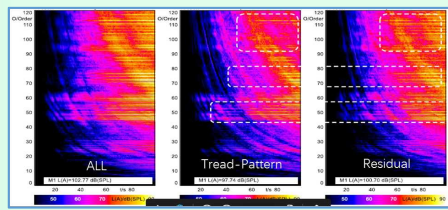
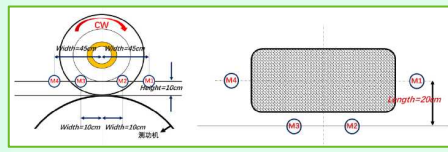
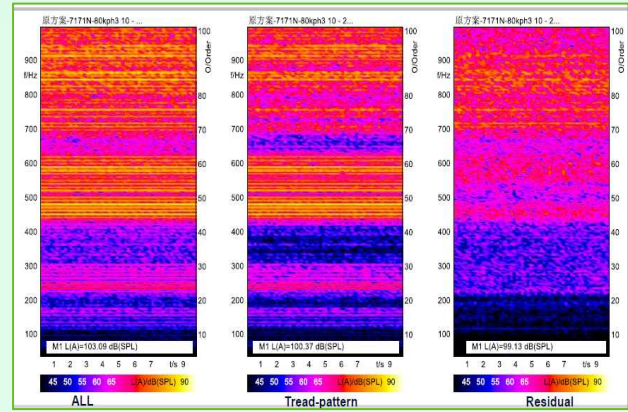
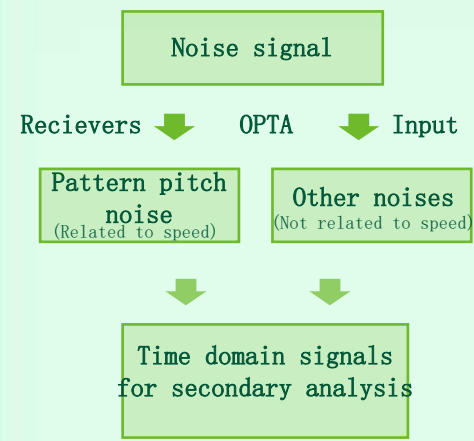

Pattern noise big data prediction

Feature extraction
technology-VGG16

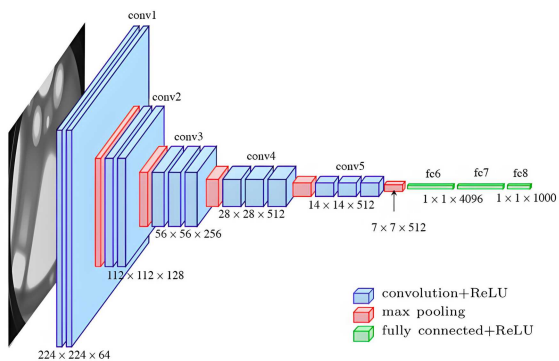

Regression prediction
technique-XGBoost

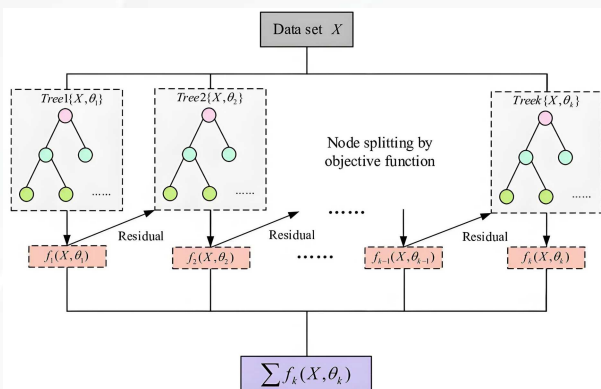

Accuracy verification

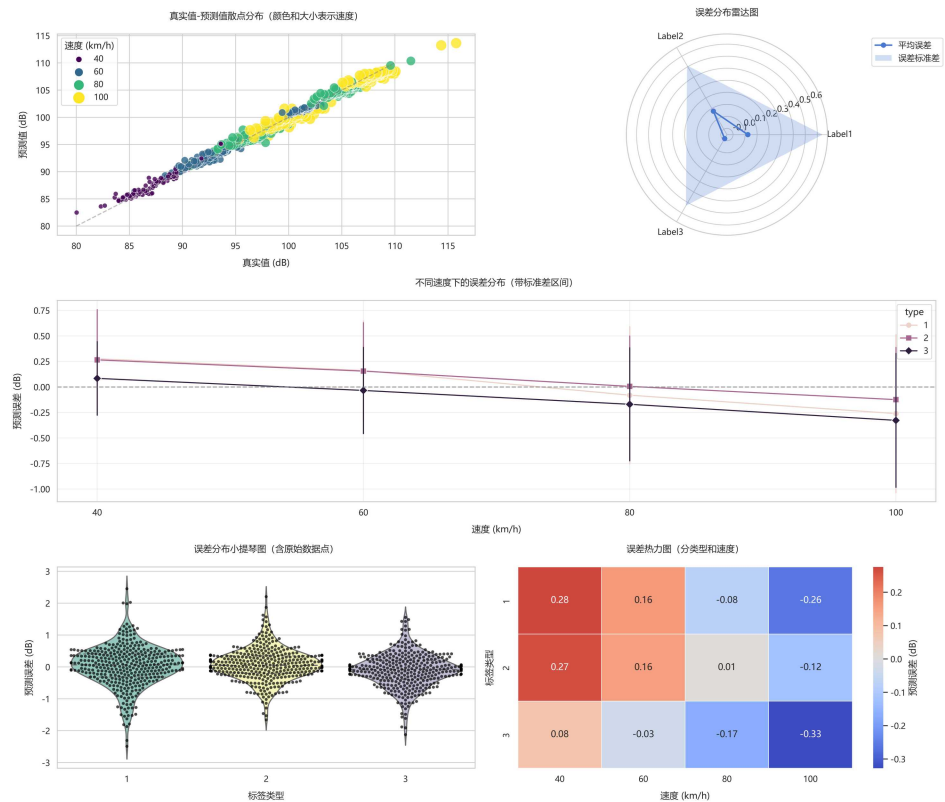

Achieve a prediction accuracy of over 90% within 1dB

Finished Product Testing – Air Spring

Bench fatigue tester



Dynamometer



Air tightness tester



Salt spray aging tester



Hydraulic burst tester



Meet constantly stringent regulatory requirements

Provide value beyond customer expectations

Vehicle Testing – Passenger Car Tires

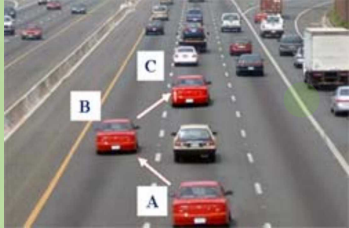

Keep straight / lane change

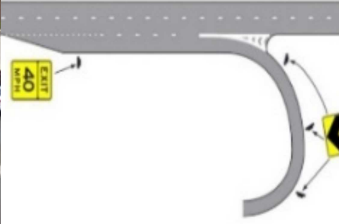

Continuous turning (such as driving off a highway intersection)



Emergency lane changing

PG test

Pass-by noise

Comfort

Dry handling

Wet handling



Continuous sharp curves



Emergency braking



Vibration and comfort

Field test

Tire wear testing

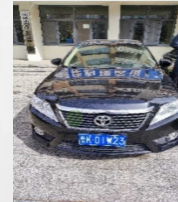

单圈总长	144km
高速	69km(47.9%)
山路	8km(5.6%)
国道、省道	67km(46.5%)

Vehicle Testing – Commercial Tires and OTR Tires

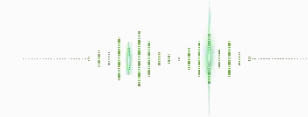

▶▶▶▶ Fuel consumption test



▶▶▶▶▶ Medium and long distance wear and eccentric wear resistance performance test



▶▶▶▶▶ Medium and short distance comprehensive performance test in mixed road conditions and mining areas



▶▶▶▶▶ Cutting and chunking resistance field test

Product Design and Development Process and Platform

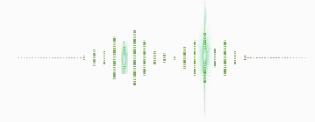

OE Market

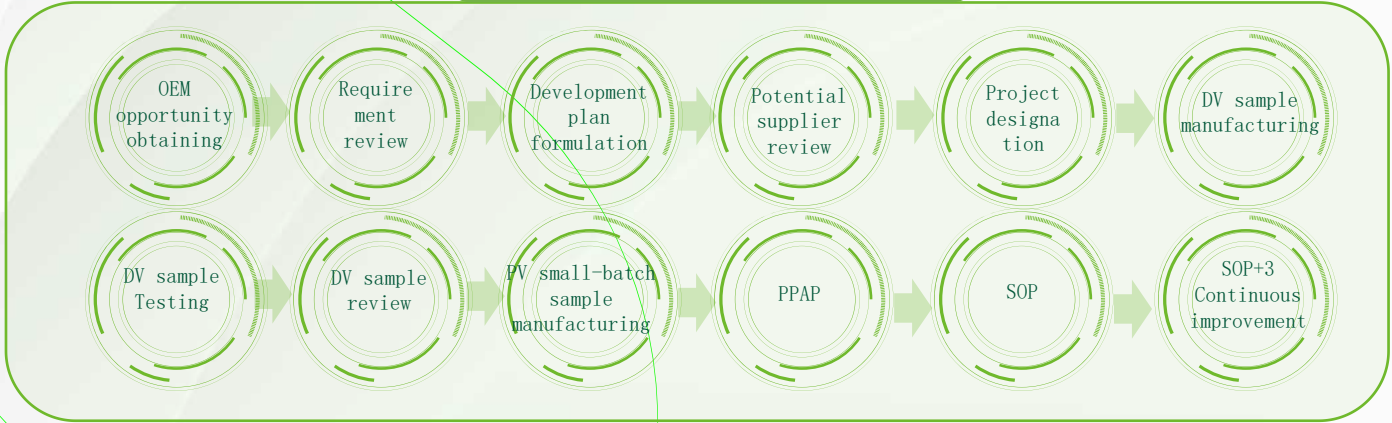

Replacement Market

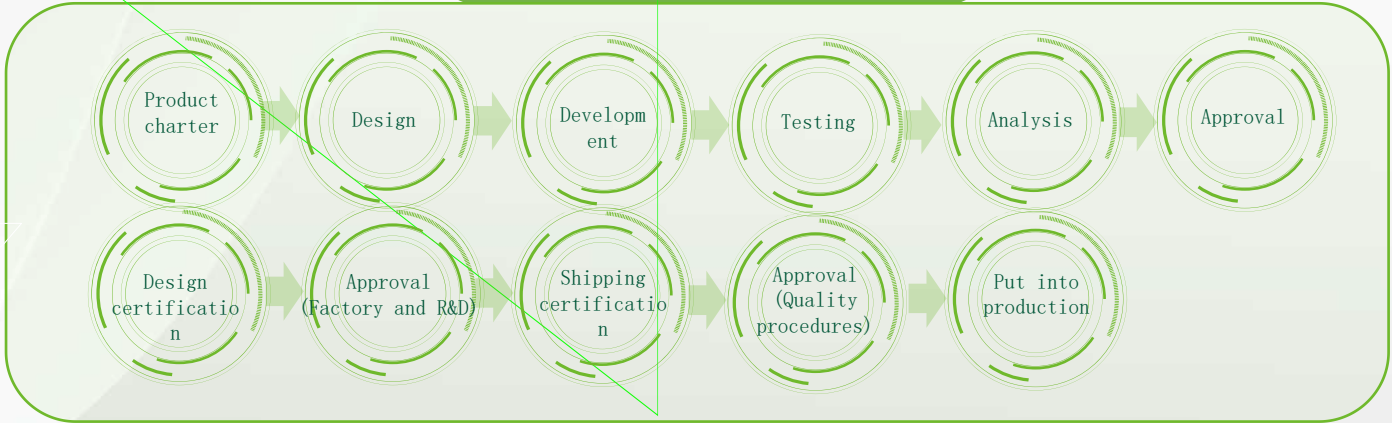

Quality Recognition and Certification

Prinx Chengshan has obtained certifications such as IATF16949, ISO14001, and ISO45001, and laboratory accreditation such as ISO17025.

Quality system certification



QMS
IATF16949



EMS
ISO14001



OHSMS
ISO45001



CNAS
ISO17025



MMS



IPMS



ENMS

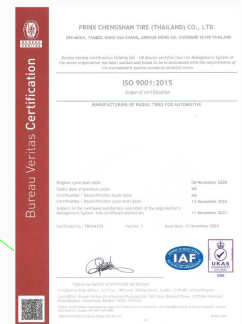

ISO9001

Product certification



International
1
Certificates



China
CCC



U. S
DOT



EU
ECE



EU
R117



Brazil
INMETRO



Gulf Area
GSO



Saudi
SASO



Nigeria
SONCAP

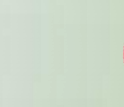

Uruguay
LATU



Thailand
TISI

Main cooperation customers in the field of passenger cars



ROEWE 荣威



We work with 36 OEMs to provide excellent services and bring your driving experience to the next level.

Main cooperation customers in the field of commercial vehicles



We work with 47 OEMs to provide excellent services and bring your driving experience to the next level.





Intelligent Manufacturing

Tandem Type Mixer

- By cooperating with well-known domestic rubber and plastic machinery factories in development of special-purpose tandem type mixer, the production efficiency is improved by 51% and energy consumption is reduced by 10% - 15%
- The constant-temperature mixing technology and efficient temperature control system based on the tandem type mixer ensure stable control of the rubber temperature during mixing, thereby optimizing the mixing effect, significantly improving performance of tires, and achieving a perfect balance between green environmental protection, high wear resistance, and low rolling resistance.

Comparison of temperature rise between conventional and tandem mixi

Time (min)	恒温过程温度/C	常规过程温度/C	恒温下限温度/C
1	145	147	145
2	148	149	145
3	150	150	145
4	151	148	145
5	152	150	145
6	155	152	145
7	156	155	145
8	158	148	145
9	159	147	145
10	159	150	145
11	162	152	145
12	164	153	145
13	165	150	145
14	166	152	145
15	168	150	145
16	168	149	145
17	170	148	145
18	171	150	145

- Rubber with good flexibility
- Easily dispersed carbon black/silica
- Functional agents

Intelligent Extrusion of Component

- By adopting an intelligent extrusion control, measurement, and rubber material switching system, the PCR extrusion qualification rate is significantly improved, to 99%.

Control principle

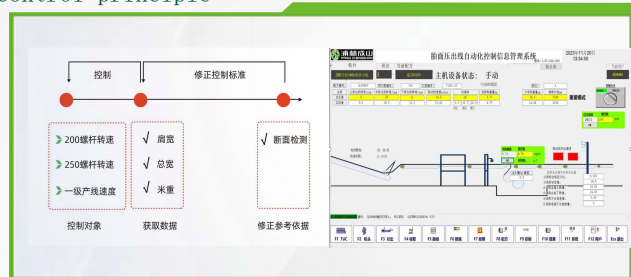

The intelligent extrusion technology developed and applied, real-time automatic detection, automatic feedback data, automatic adjustment of linkage linear speed improve stability of process parameters and qualification rate of products.

Tread width detection system



Intelligent extrusion improves the weight consistency and dynamic balance level of component and finished tires, meeting the needs of dealers and customers.

Start of rubber discharging



The intelligent rubber discharging and changing program and automatic switching of rubber prevents performance from being affected by mixing of rubber types.

End of rubber discharging

Five-compound Extrusion Technology for Tread

- ▶▶▶▶ The application of low-carbon new energy drives a new power revolution, therefore new energy vehicles have higher requirements for rolling resistance, fuel efficiency, and electrostatic discharge.
- ▶▶▶▶ We cooperate with first-tier manufacturers in China to develop a five-compound tread extrusion linkage line, which can upgrade the traditional two/three compound tread structure to a five-compound structure.
- ▶▶▶▶ The advantages of five-compound tread products include low heat generation, low rolling resistance, high wear resistance, and high durability. The durability performance is improved by 10%.

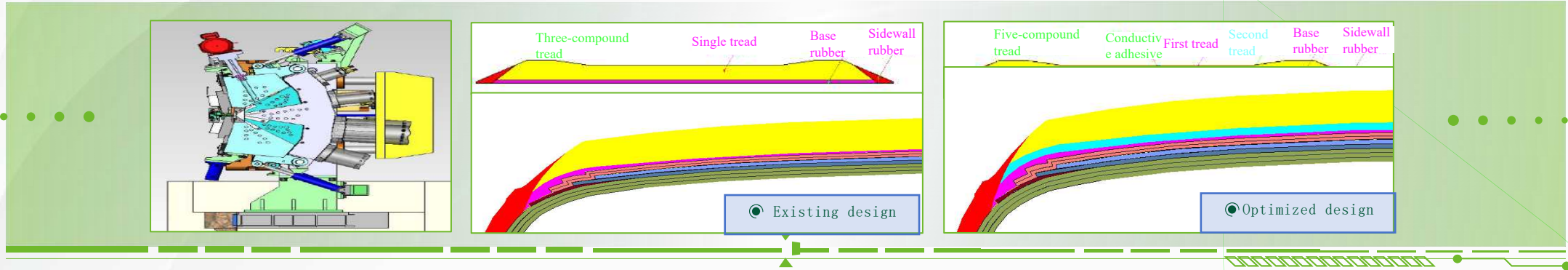

Building Automation

● Main member of VMI family - EXXIUM fully automatic single-stage building machine ● MESNAC two-stage building machine, with the first stage operated on flat drum, and the second stage equipped with automatic robot

- ▶▶▶▶ Fully automatic
- ▶▶▶▶ High precision
- ▶▶▶▶ Stability
- ▶▶▶▶ 3D visual detection

The inner liner is fitted with the carcass smoothly, and the joints are inspected automatically

Components are applied automatically

The labor intensity is decreased by 50%

The whole machine can be operated by one person

New Dual-tread Technology

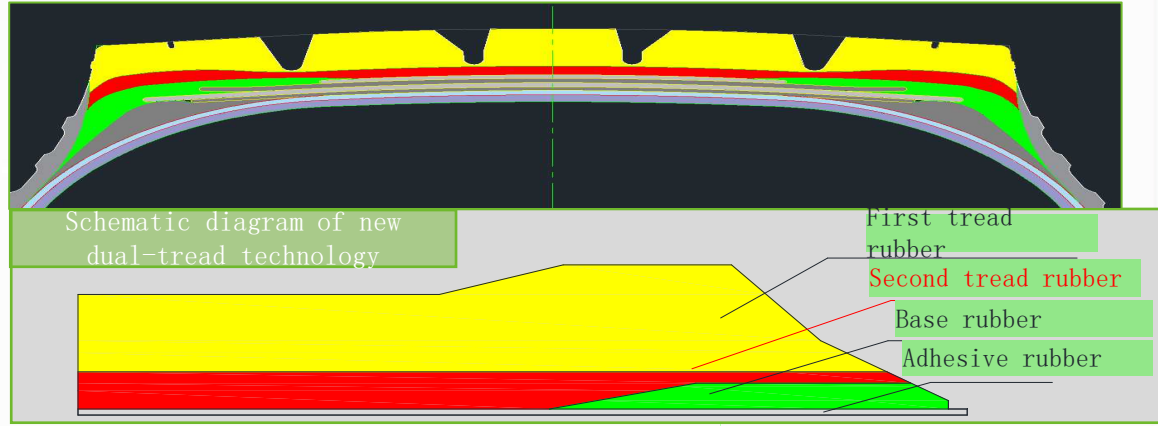
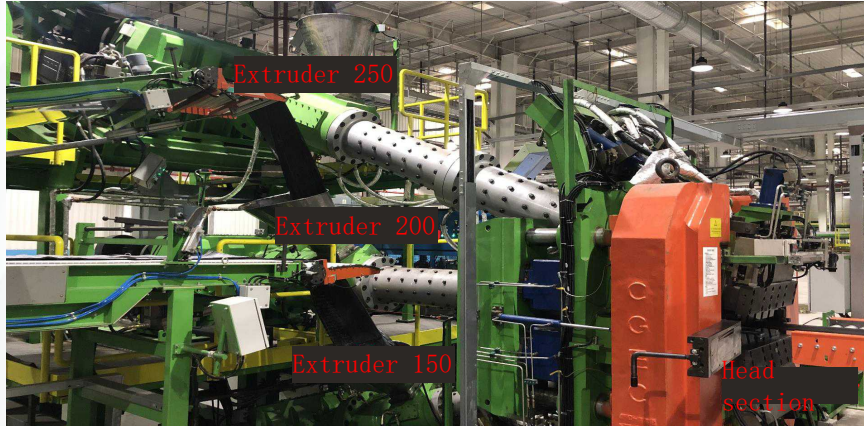

▶▶▶ The new dual-tread technology is produced by advanced triple compound extruder, adding second layer of tread on the basis of traditional tread.

▶▶▶ The advantages of dual-tread products include low heat generation, low rolling resistance, high wear resistance, and high durability. **The durability performance is improved by 20%.**

Five-drum Tire Building Machine

▶▶▶ Research on intelligent flexible thermal application technology for tread

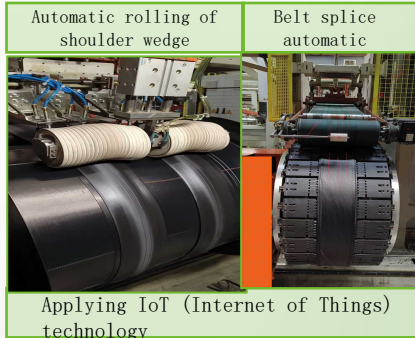

It has been successfully developed and filled the gap in domestic high automation and high-quality building machines for TBR tires. The first five-drum building machine for TBR tires at home and abroad and tread winding technology, optimize the production process of and improve tire quality. And, it was awarded the Excellent Achievement Award for Enterprise Brand Innovation in Shandong Province.

Intelligent Logistics

Digital error prevention of materials

- Radio frequency identification technology (RFID)

RFID is a type of automatic identification technology that achieves non-contact bidirectional data communication by radio frequency identification. It achieves reading and writing of electronic tags by radio frequency identification, thereby achieving the purpose of identifying targets and exchanging data. It is an important technology for achieving intelligent manufacturing. With the help of RFID technology, automatic identification and feeding of materials can be achieved. And MES system can be used to achieve automatic error prevention, thereby achieving intelligent management.

RFID identification during rubber mixing



Trigger photoelectric sensors to read RFID
Scan and identify rubber material information to prevent accidental feeding

Identification for feeding of components



MES scans and identifies rubber material information to prevent accidental feeding

Binding carrier with RFID



Trigger the photoelectric sensor to read RFID, allowing for querying of work-in-progress inventory and avoiding inaccurate inventory

Material barcode and automatic printing and scanning



Barcodes are used for batch management to achieve bidirectional traceability control in the production

RFID identification of devices

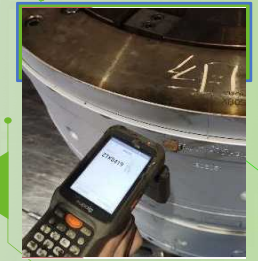

The mold state is scanned and recognized to prevent misoperation

Digital transportation of materials

By utilizing intelligent equipment (such as AGV, EMS carts, three-dimensional warehouses, and truss manipulators) and efficient scheduling systems, the materials in various processes are linked to achieve a full process logistics management mode, making logistics transportation timely and efficient, achieving transparency in logistics operation and real-time monitoring of the entire process.

Transportation of components



Timely scheduling of central control system, three-dimensional storage, and convenient out-put and in-put of storage

Green tire



Storage in a three-dimensional warehouse and transportation by a stacker crane

Directional conveying



EMS intelligent car conveying

Finished tire delivery

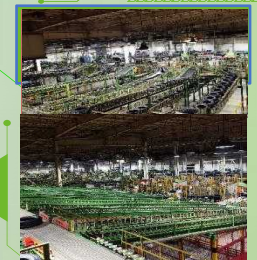

After vulcanization, it is automatically transported to the visual inspection and dynamic balance/uniformity test area

Intelligent Logistics

Digitalization of product information

MES is a key technology for realizing digital factories, building intelligent factories, and achieving intelligent manufacturing. It is the soul of intelligent manufacturing and the intersection that runs through various links (production, engineering technology, and production manufacturing). The goal of MES is to implement management concepts such as Lean Production (LP), Just in Time (JIT), Total Quality Management (TQM), Total Productive Maintenance (TPM), and Overall Equipment Effectiveness (OEE), achieve a transparent, visible, and rapid response, as well as closed-loop management model, and connect the entire process control from raw materials to out-put of storage.

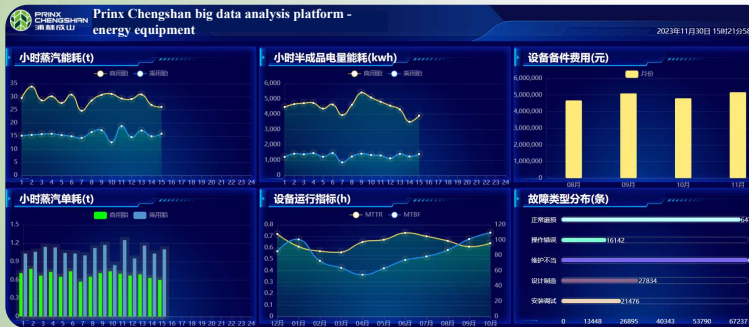
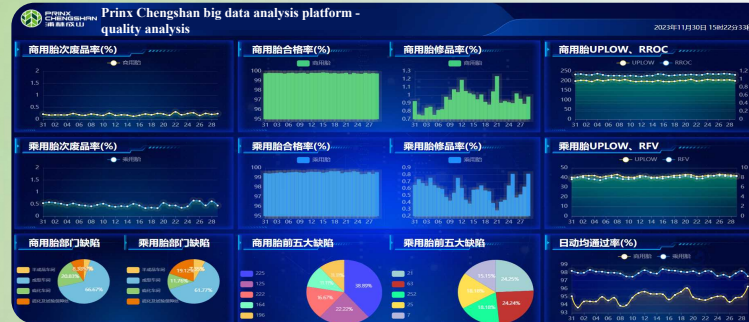

Intelligent Control System

- By utilizing advanced automation control system and component online inspection, real-time analysis and feedback can be achieved, improving stability of the production process and effectively ensuring quality consistency.



Control time and temperature and analyze power curve to ensure consistency in rubber material performance



Ensure accurate weighing and eliminate human interference



Perfect real-time display and traceability enable timely and effective control of quality issues during production



Feed back fluctuations in size and weight of extruded components in a real-time way

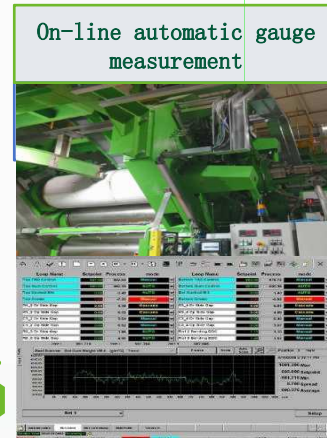

Hydraulic servo distance adjustment and automatic gauge measurement is equipped to ensure thickness of fabric and uniformity of the coating rubber.

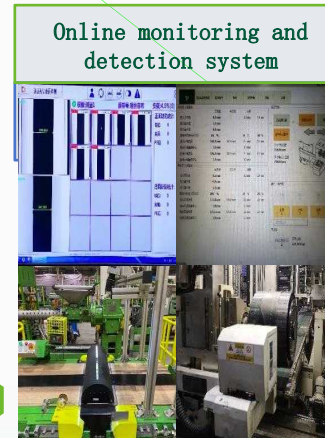

Achieve real-time collection and monitoring of various processing parameters



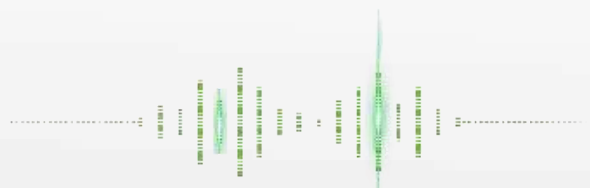

Digital Intelligence Services

Road Rescue Contact List

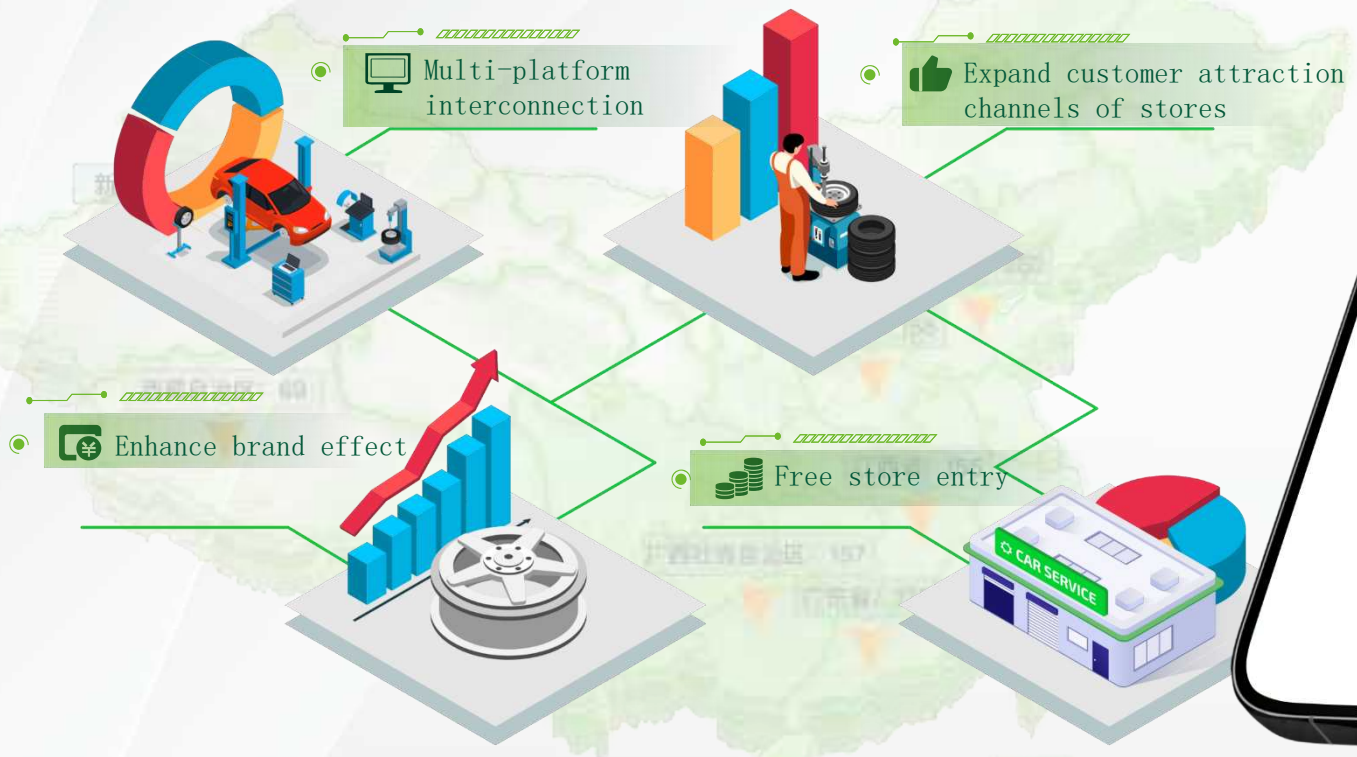

Digital Channel

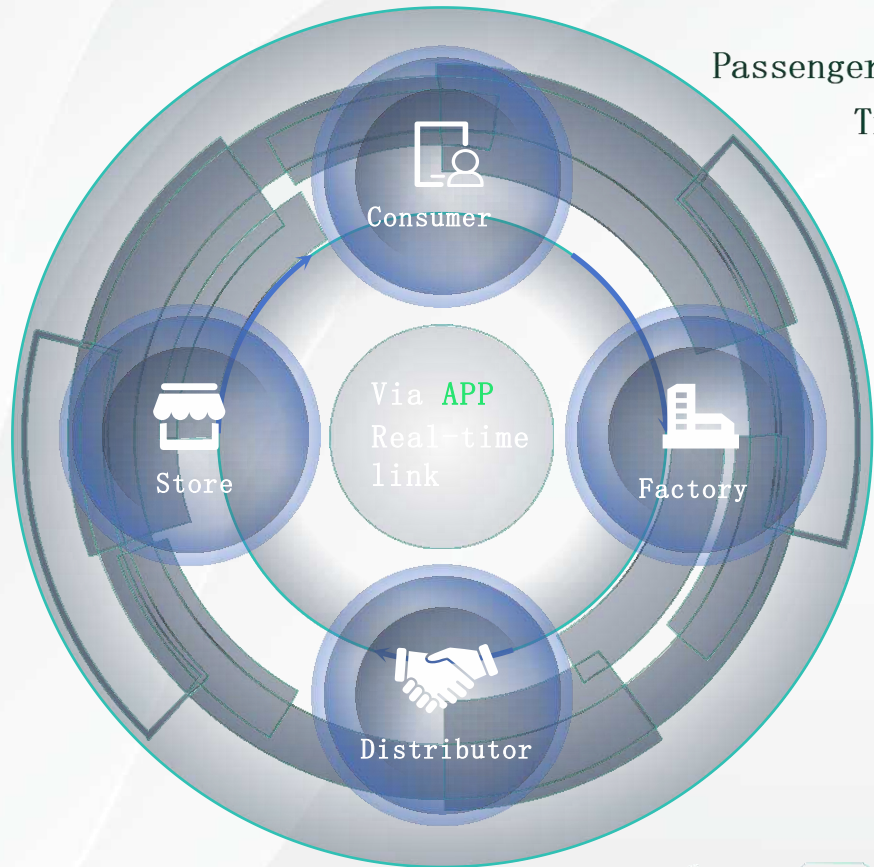

Diversified layout of digital channels

Passenger car: Xiaopu Cloud Store Commercial vehicle: Lighthouse E-Station

Transformation and upgrading, helping stores to create wealth

Vendor
transaction
Store
transaction
Consumer
service



灯塔e站

Empower the marketing network and optimize the sales structure with over 8,000 registered stores.



小浦云店

Leverage digital marketing tools to support channel sales and improve tire turnover efficiency, with more than 25,800 registered stores.



小浦爱家

Establish a trinity protection system integrating consumers, stores and platforms to safeguard consumer rights and interests.

Intelligent Tire Management



The intelligent tire management system is built based on personalized customer requirements and IoT thinking to achieve professional management of tires with sensors and backend servers.

Smart Carpooling

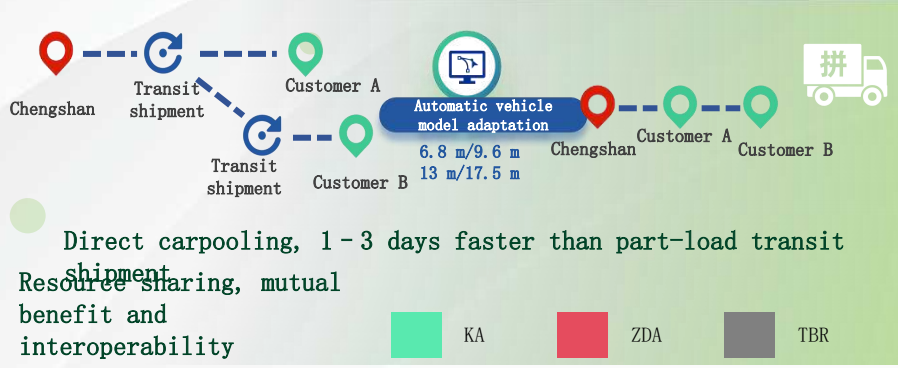

Inventory Sharing

Zhangjiagang Jindeyi Trading Co., Ltd. (customer's warehouse)

Service scope: Supporting KA customers in Jiangsu, Zhejiang, and Shanghai region, as well as Zhianda customers in Guangdong Province

Mode: Customer custody and sharing

Shipment: 3 times, 108 pcs

Duration: 0.5-1 days

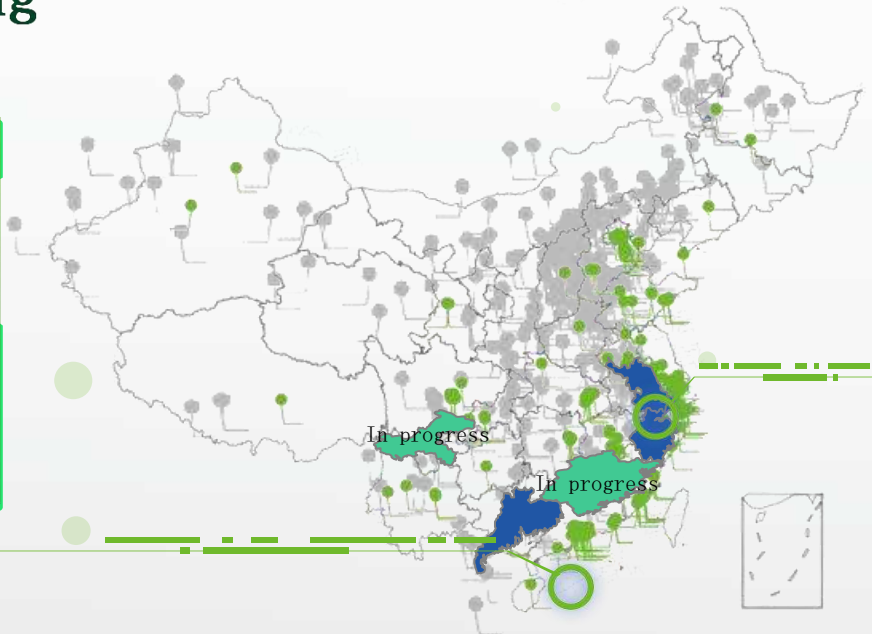

Guangzhou No. 28th Company (directly affiliated warehouse)

Service scope: Supporting KA customers in Guangdong region, as well as Zhianda customers in Guangdong Province

Mode: Directly affiliated warehouse

Shipment: 117 times, 9,800 pcs

Duration: 0.5-1 days

All-round Services

Provide integrated solutions based on the pain points of end customers

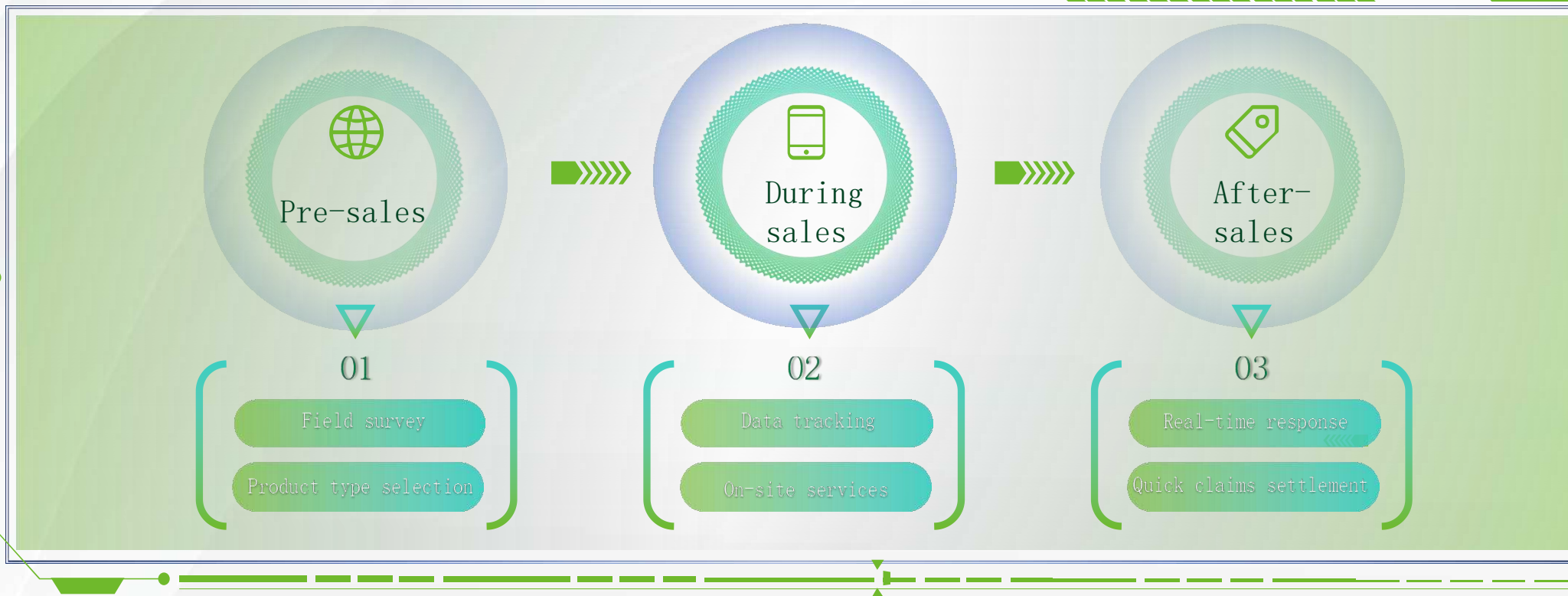

All-round Services

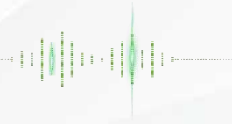

Expert-level Qualification

▼ All the market service personnel have passed the training of "National Rubber Tire Quality Supervision and Inspection Center" and obtained the Qualification Certificate of Automobile Tire Claimer.

Advisory Services

▼ Experts with 20 years of rich experience directly enter the terminal market to provide customers with the best tire fault diagnosis solutions.

Extra-long Warranty Period

▼ The warranty period of each tire is 4 years from the production day.

Technical Services

▼ R&D personnel regularly visit and conduct market research to collect information and provide feedback, and to improve and enhance products.

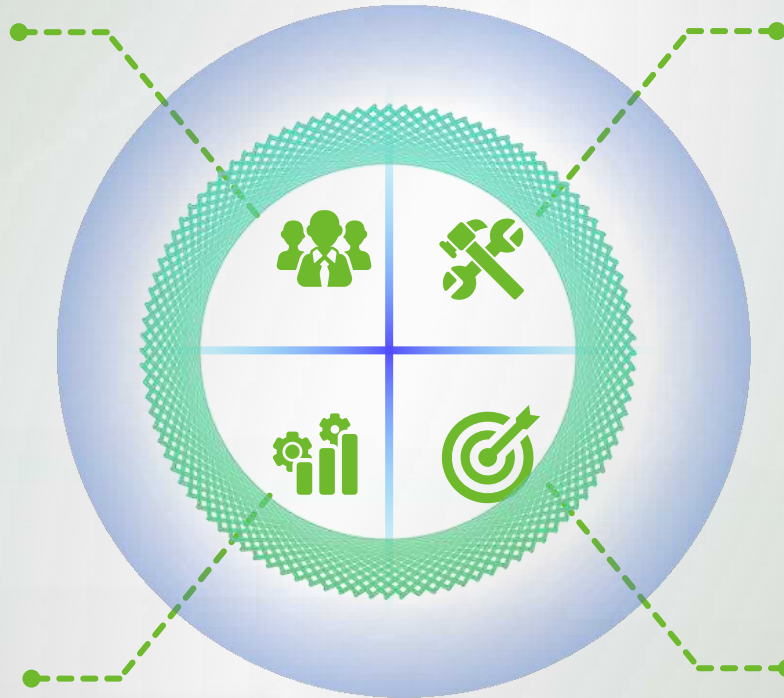

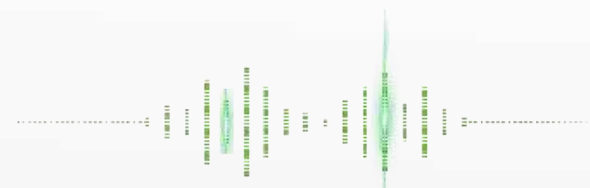

Brand Marketing



Differentiated development of multiple brands

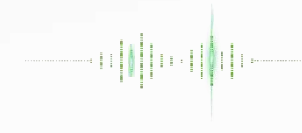

PRINX

LEAVE YOUR MARK

PRINX
XLAB COMFORT EV
(215/35R17)

CHENGSHAN

STRONG TIRE FOR LONGER PERFORMANCE

CHENGSHAN

CHENGSHAN

AUSTONE TIRES

Make it Count

Love is the origin, is the drive for life.

austonetire.com

AUSTONE TIRES

FORTUNE TIRES

DRIVE FORWARD

FORTUNE TIRES

Marketing Activities



Prinx "Sparkling Elf Series" Colored Tire New Product Launch and Xiaomi SU7 Test Drive Event

Marketing Activities



Marketing Activities



Marketing Activities



Prinx Chengshan Presents at the FIA European Truck Racing Championship

Marketing Activities



Prinx Tire Featured on Consumer View, the Flagship Program of CCTV-2 Finance Channel



ESG

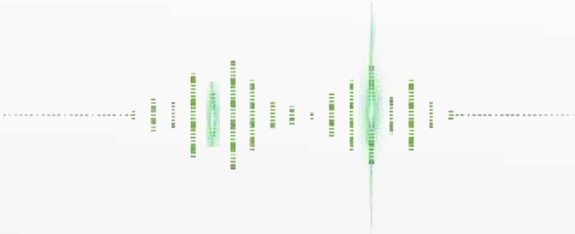

Award Certification

BRONZE | Top 35%

ecovadis

Sustainability Rating

JAN 2025



social
responsibility

Prinx Chengshan has achieved a remarkable milestone on the global corporate social responsibility (CSR) stage. Competing for the internationally renowned EcoVadis certification for the first time, the company stood out among strong contenders, successfully ranking in the top 35% worldwide and earning the prestigious EcoVadis Bronze Medal.

Winning the EcoVadis Bronze Medal is a strong validation of Prinx Chengshan's long-standing commitment to green development and social responsibility.

Conceptual Goals

Adhering to the vision and mission of leading innovation of tires, making contributions to smart transportation and sustainable development, and achieving a better life, as well as the core values of customer first, responsibility, professionalism, innovation, and openness, Prinx Chengshan takes the principle of sustainable development as the foundation of its development strategies and daily operations, and adheres to the concept of people-oriented, research and development of innovative products, and green and sustainable development.

- The proportion of low rolling resistance products for commercial vehicle tires and passenger car tires reached 45% and 50%, respectively.

Emission
reduction
Target

- Compared to 2021, the CO2 emissions per unit product generated during tire production (including tire retreading) have decreased by 27%.
- The solar power generation is more than three times that of 2021.

Waste
Target

- Compared to 2021, the amount of general waste produced per unit product has decreased by 4.3%;
- Compared to 2021, the amount of hazardous waste produced per unit product has decreased by 18.2%.

Water
consumption
Target

- Compared to 2021, the water consumption per unit product has decreased by approximately 50%

- Compared to 2021, the water consumption per unit product has decreased by approximately 50%

2025

2030

Green Manufacturing

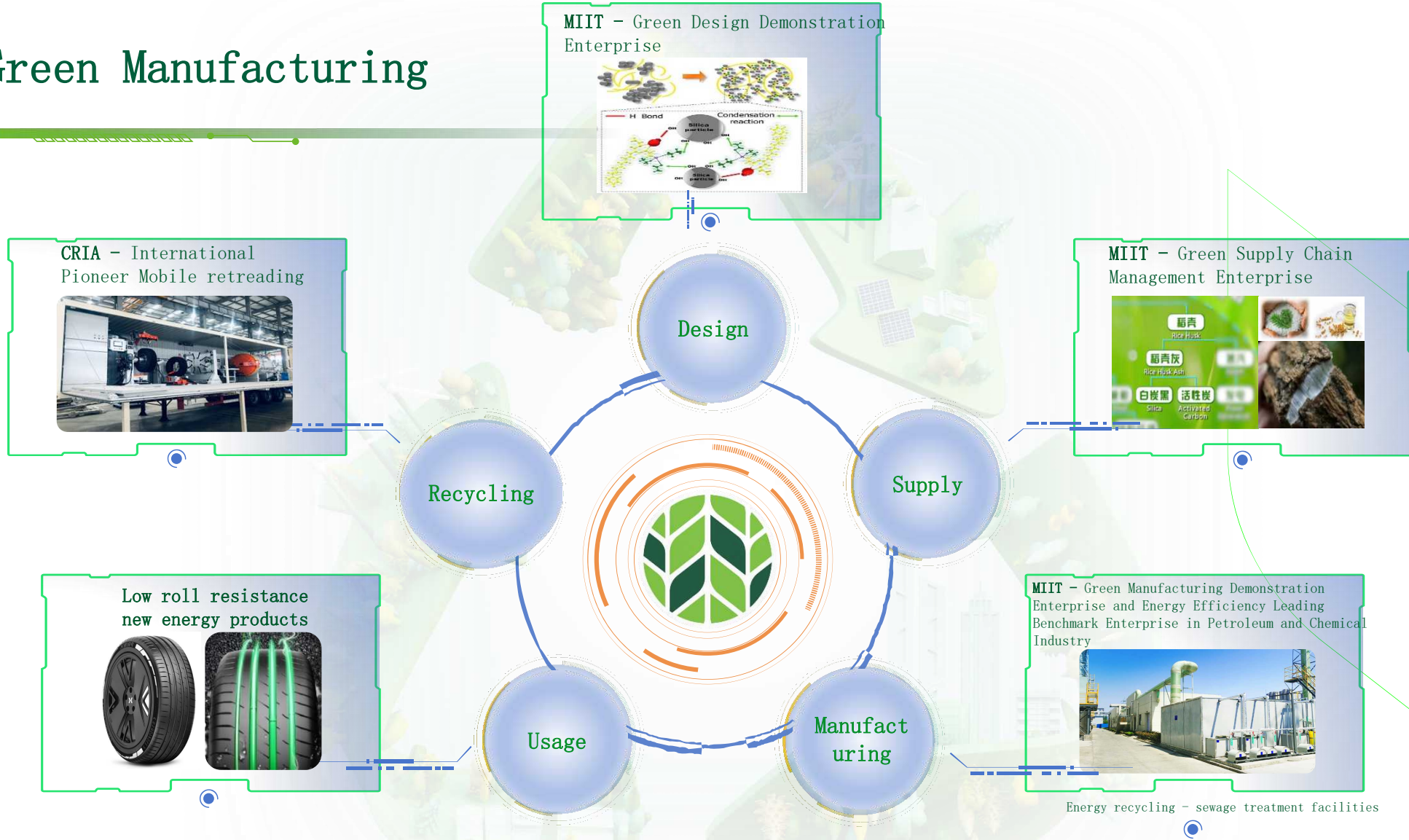

Prinx Chengshan is committed to continuously improving green design of tires to enhance their environmental friendliness. By data collection and modeling via Life Cycle Assessment (LCA), the environmental impact of each stage from procurement, production, transportation, sales, usage to raw material disposal is regularly evaluated.

Social Responsibility

Won the 2020 Annual "Responsibility Brand Award" and "Social Responsibility of Listed Companies Award" in 10th China Charity Festival



Won the Social Responsibility Award of Listed Companies in China Charity Festival 2019





Together, a better life